



AXON Runway Inset Lights, 8-inch and 12-inch
ICAO &FAA, L-850A(L) Centerline; ICAO &FAA L-850B(L)
Touchdown Zone; ICAO &FAA L-850C(L) Edge 45m;
ICAO &FAA L-850D(L) End; FAA Threshold &Threshold/End
L-850D(L); ICAO Stopway; ICAO &FAA L-850T(L) Takeoff/Hold
(THL)&(RIL)Runway Intersection

User Manual

UM-5055, Rev. 1.0.17, 2022/12/14

**ADB
SAFEGATE**

A.0 Disclaimer / Standard Warranty

CE certification

The equipment listed as CE certified means that the product complies with the essential requirements concerning safety and hygiene. The European directives that have been taken into consideration in the design are available on written request to ADB SAFEGATE.

ETL certification

The equipment listed as ETL certified means that the product complies with the essential requirements concerning safety and FAA Airfield regulations. The FAA directives that have been taken into consideration in the design are available on written request to ADB SAFEGATE.

All Products Guarantee

ADB SAFEGATE will correct by repair or replacement per the applicable guarantee above, at its option, equipment or parts which fail because of mechanical, electrical or physical defects, provided that the goods have been properly handled and stored prior to installation, properly installed and properly operated after installation, and provided further that Buyer gives ADB SAFEGATE written notice of such defects after delivery of the goods to Buyer. Refer to the Safety section for more information on Material Handling Precautions and Storage precautions that must be followed.

ADB SAFEGATE reserves the right to examine goods upon which a claim is made. Said goods must be presented in the same condition as when the defect therein was discovered. ADB SAFEGATE further reserves the right to require the return of such goods to establish any claim.

ADB SAFEGATE's obligation under this guarantee is limited to making repair or replacement within a reasonable time after receipt of such written notice and does not include any other costs such as the cost of removal of defective part, installation of repaired product, labor or consequential damages of any kind, the exclusive remedy being to require such new parts to be furnished.

ADB SAFEGATE's liability under no circumstances will exceed the contract price of goods claimed to be defective. Any returns under this guarantee are to be on a transportation charges prepaid basis. For products not manufactured by, but sold by ADB SAFEGATE, warranty is limited to that extended by the original manufacturer. This is ADB SAFEGATE's sole guarantee and warranty with respect to the goods; there are no express warranties or warranties of fitness for any particular purpose or any implied warranties of fitness for any particular purpose or any implied warranties other than those made expressly herein. All such warranties being expressly disclaimed.

Standard Products Guarantee

Products manufactured by ADB SAFEGATE are guaranteed against mechanical, electrical, and physical defects (excluding lamps) which may occur during proper and normal use for a period of two years from the date of ex-works delivery, and are guaranteed to be merchantable and fit for the ordinary purposes for which such products are made.



Note

See your applicable sales agreement for a complete warranty description.

Replaced or repaired equipment under warranty falls into the warranty of the original delivery. No new warranty period is started for these replaced or repaired products.

FAA Certified products manufactured by ADB SAFEGATE

ADB SAFEGATE L858 Airfield Guidance Signs are warranted against mechanical and physical defects in design or manufacture for a period of 2 years from date of installation, per FAA AC 150/5345-44 (applicable edition).

ADB SAFEGATE LED products (with the exception of obstruction lighting) are warranted against electrical defects in design or manufacture of the LED or LED specific circuitry for a period of 4 years from date of installation, per FAA EB67 (applicable edition). These FAA certified constant current (series) powered LED products must be installed, interfaced and powered with and through products certified under the FAA Airfield Lighting Equipment Program (ALECP) to be included in this 4 (four) year warranty. This includes, but is not limited to, interface with products such as Base Cans, Isolation Transformers, Connectors, Wiring, and Constant Current Regulators.



Note

See your sales order contract for a complete warranty description.

Replaced or repaired equipment under warranty falls into the warranty of the original delivery. No new warranty period is started for these replaced or repaired products.

Liability



WARNING

Use of the equipment in ways other than described in the catalog leaflet and the manual may result in personal injury, death, or property and equipment damage. Use this equipment only as described in the manual.

ADB SAFEGATE cannot be held responsible for injuries or damages resulting from non-standard, unintended uses of its equipment. The equipment is designed and intended only for the purpose described in the manual. Uses not described in the manual are considered unintended uses and may result in serious personal injury, death or property damage.

Unintended uses, includes the following actions:

- Making changes to equipment that have not been recommended or described in this manual or using parts that are not genuine ADB SAFEGATE replacement parts or accessories.
- Failing to make sure that auxiliary equipment complies with approval agency requirements, local codes, and all applicable safety standards if not in contradiction with the general rules.
- Using materials or auxiliary equipment that are inappropriate or incompatible with your ADB SAFEGATE equipment.
- Allowing unskilled personnel to perform any task on or with the equipment.

© ADB SAFEGATE SWEDEN AB

This manual or parts thereof may not be reproduced, stored in a retrieval system, or transmitted, in any form or by any means, electronic, mechanical, photocopying, recording, nor otherwise, without ADB SAFEGATE SWEDEN AB's prior written consent.

This manual could contain technical inaccuracies or typographical errors. ADB SAFEGATE SWEDEN AB reserves the right to revise this manual from time to time in the contents thereof without obligation of ADB SAFEGATE SWEDEN AB to notify any person of such revision or change. Details and values given in this manual are average values and have been compiled with care. They are not binding, however, and ADB SAFEGATE SWEDEN AB disclaims any liability for damages or detriments suffered as a result of reliance on the information given herein or the use of products, processes or equipment to which this manual refers. No warranty is made that the use of the information or of the products, processes or equipment to which this manual refers will not infringe any third party's patents or rights. The information given does not release the buyer from making their own experiments and tests.

© ADB SAFEGATE BV

This manual or parts thereof may not be reproduced, stored in a retrieval system, or transmitted, in any form or by any means, electronic, mechanical, photocopying, recording, nor otherwise, without ADB SAFEGATE BV's prior written consent.

This manual could contain technical inaccuracies or typographical errors. ADB SAFEGATE BV reserves the right to revise this manual from time to time in the contents thereof without obligation of ADB SAFEGATE BV to notify any person of such revision or change. Details and values given in this manual are average values and have been compiled with care. They are not binding, however, and ADB SAFEGATE BV disclaims any liability for damages or detriments suffered as a result of reliance on the information given herein or the use of products, processes or equipment to which this manual refers. No warranty is made that the use of the information or of the products, processes or equipment to which this manual refers will not infringe any third party's patents or rights. The information given does not release the buyer from making their own experiments and tests.

TABLE OF CONTENTS

1.0 Safety	1
1.1 Safety Messages	1
1.1.1 Introduction to Safety	2
1.1.2 Intended Use	2
1.1.3 Material Handling Precautions: Storage	3
1.1.4 Operation Safety	3
1.1.5 Maintenance Safety	3
1.1.6 Material Handling Precautions: Fasteners	4
1.1.7 Material Handling Precautions, ESD	4
2.0 About this Manual	5
2.1 How to work with the Manual	5
2.2 Abbreviations and Terms	5
3.0 Introduction	7
3.1 Product Information	8
3.2 Dimensions and Weight	12
4.0 Installation	13
4.1 Unpacking the Unit	13
4.2 Tools required	13
4.3 Installation	13
4.3.1 Installation Overview	14
4.3.2 Installation and Removal of the 12-inch Light Fixture	16
4.4 Toe-in	17
4.5 Light Emission Directions	19
4.5.1 Definition of Light Emission Directions	19
5.0 Maintenance	21
5.1 Basic Maintenance Program	21
5.2 Recommended Maintenance Program for optimal Service Life	22
5.2.1 Recommendation	24
5.3 Workshop Maintenance	26
5.3.1 Opening a Light Fixture — disconnecting the Bottom Pan from the Top Cover	26
5.3.2 Close a Light Fixture — connect the Bottom Pan to the Top Cover	27
5.3.3 Replace the Wire Harnesses	29
5.3.4 Replace the Light Engine Assembly	30
5.3.5 Replace the Prism and its Gasket	30
5.3.6 Replace the Top Cover Assembly	34
5.3.7 Replace the Bottom Cover Assembly	35
5.3.8 Replace the secondary Cable — SJO cord set	35
5.3.9 Replace the secondary Cable — Style-6 cord set	39
5.3.10 Replace the secondary Cable — French 3-pin cord set	43
5.3.11 Reset the Fail-open Converter	47
5.3.12 Check the Light Fixture for Water-tightness	48
6.0 Ordering Codes	51
6.1 Ordering Code L-850C(L) Runway Edge 45m ICAO & FAA	52
6.2 Ordering Code L-850A(L) Runway Centerline , L-850B(L) Touchdown Zone (ICAO & FAA)	54
6.3 Ordering Code Threshold, End & Threshold/End L-850D(L) (FAA)	56
6.4 Ordering Code ICAO & FAA L-850T(L) Takeoff/Hold (THL) & (RIL)Runway Intersection	58
6.5 Ordering Code Stopway 45m (ICAO)	59
7.0 Spare Parts	61
7.1 Versions and Exploded View	61
7.2 Spare Parts - Runway Edge 45m ICAO & FAA	62
7.3 Spare Parts - Centerline ICAO & FAA	65
7.4 Spare Parts - Touchdown Zone ICAO & FAA	70

7.5 Spare Parts - Threshold FAA, Threshold/End FAA, Runway End ICAO & FAA	74
7.6 Spare Parts - Runway Status, Takeoff/Hold, Runway Intersection and Runway Entry Light	77
8.0 Definition of Light Emission Directions	81
A.0 POWER TABLE	83
B.0 INTEROPERABILITY	85
C.0 CABLE LOSS	89
D.0 SUPPORT	91
D.1 ADB SAFEGATE Website	91
D.2 Recycling	91
D.2.1 Local Authority Recycling	91
D.2.2 ADB SAFEGATE Recycling	92

List of Figures

Figure 1: 12-inch and 8-inch Fixtures	7
Figure 2: 12-inch and 8-inch Fixtures	12
Figure 3: Installation on 8" shallow base	14
Figure 4: Diagram of the Fixture Installed in a 1-Piece Base Can	15
Figure 5: Anti-vibration washer example	15
Figure 6: 12-in shallow base, class 1, direct-mounted fixtures	16
Figure 7: Toe-in	18
Figure 8: Light emission directions	19
Figure 9: Preventive Maintenance	23
Figure 10: Visual Inspection Interval	24
Figure 11: Loosening Pressure Release Screw	27
Figure 12: Gasket Placement	28
Figure 13: Top cover placement	28
Figure 14: Dispose old wire harnesses	29
Figure 15: Removal of light engine(s) assembly	30
Figure 16: Removal of light engine(s) assembly	30
Figure 17: Removal of the prism-keeper plate and prism-protection gap pad	31
Figure 18: Prism protection gap pad placement	31
Figure 19: Prism-keeper plate installation into the top cover	32
Figure 20: Mounting procedure	32
Figure 21: Light engine assembly mounting procedure	33
Figure 22: Dispose old screws and old top cover	34
Figure 23: Sequence	34
Figure 24: Secondary cable replacement	35
Figure 25: Disconnecting secondary cable	36
Figure 26: Dispose old bolt and cord-set-retainer disc	36
Figure 27: Dispose old bolt, washer and lock washer	36
Figure 28: New cable gland gasket installation	37
Figure 29: Loosen the cord-set-retainer disc in the bottom cover	37
Figure 30: Installation steps overview	38
Figure 31: Locking secondary cables	38
Figure 32: Secondary cable replacement	39
Figure 33: Disconnecting secondary cable	39
Figure 34: Removal of nylon hex nut	40
Figure 35: Dispose old bolt and cord-set-retainer disc	40
Figure 36: New cable gland gasket installation	40

Figure 37: Loosen cord-set-retainer disc in the bottom cover	41
Figure 38: Installation of secondary cable	41
Figure 39: Secure nylon hex nut tightly with a wire tie	41
Figure 40: Tighten new cold-set-retainer bolt	42
Figure 41: Locking secondary cables	42
Figure 42: Disconnecting secondary cable	43
Figure 43: Removal of nylon hex nut	43
Figure 44: Dispose old bolt and cord-set-retainer-disc	44
Figure 45: Dispose old bolt and washer	44
Figure 46: Installation of new cable gland gasket	44
Figure 47: Loosen cord-set-retainer disc in the bottom cover	45
Figure 48: Installation of new secondary wires	45
Figure 49: Securing nylon hex nut tightly with a wire tie	45
Figure 50: Tighten new cold-set-retainer bolt	46
Figure 51: Tighten bolt	46
Figure 52: Locking secondary cables	46
Figure 53: Converter 1	47
Figure 54: Converter 2	47
Figure 55: Removal of pressure-relief screw	48
Figure 56: Screw the fitting hand-tight	49
Figure 57: 8-inch fixtures (left) & 12-inch fixtures(right)	61
Figure 58: Light emission directions	81

List of Tables

Table 1: Exploded View Legend — Spare part assemblies, 8-inch and 12-inch	61
Table 2: Interoperability matrix — 12 inch	86
Table 3: Interoperability matrix — 8 inch	86

1.0 Safety

Introduction to Safety







This section contains general safety instructions for installing and using ADB SAFEGATE equipment. Some safety instructions may not apply to the equipment in this manual. Task- and equipment-specific warnings are included in other sections of this manual where appropriate.

1.1 Safety Messages

HAZARD Icons used in the manual

For all HAZARD symbols in use, see the Safety section. All symbols must comply with ISO and ANSI standards.

Carefully read and observe all safety instructions in this manual, which alert you to safety hazards and conditions that may result in personal injury, death or property and equipment damage and are accompanied by the symbol shown below.

	<p>WARNING Failure to observe a warning may result in personal injury, death or equipment damage.</p>
	<p>DANGER - Risk of electrical shock or ARC FLASH Disconnect equipment from line voltage. Failure to observe this warning may result in personal injury, death, or equipment damage. ARC Flash may cause blindness, severe burns or death.</p>
	<p>WARNING - Wear personal protective equipment Failure to observe may result in serious injury.</p>
	<p>WARNING - Do not touch Failure to observe this warning may result in personal injury, death, or equipment damage.</p>
	<p>CAUTION Failure to observe a caution may result in equipment damage.</p>
	<p>ELECTROSTATIC SENSITIVE DEVICES This equipment may contain electrostatic devices.</p>

Qualified Personnel

	<p>Important Information The term qualified personnel is defined here as individuals who thoroughly understand the equipment and its safe operation, maintenance and repair. Qualified personnel are physically capable of performing the required tasks, familiar with all relevant safety rules and regulations and have been trained to safely install, operate, maintain and repair the equipment. It is the responsibility of the company operating this equipment to ensure that its personnel meet these requirements. Always use required personal protective equipment (PPE) and follow safe electrical work practice.</p>
---	---

1.1.1 Introduction to Safety



CAUTION

Unsafe Equipment Use

This equipment may contain electrostatic devices, hazardous voltages and sharp edges on components

- Read installation instructions in their entirety before starting installation.
- Become familiar with the general safety instructions in this section of the manual before installing, operating, maintaining or repairing this equipment.
- Read and carefully follow the instructions throughout this manual for performing specific tasks and working with specific equipment.
- Make this manual available to personnel installing, operating, maintaining or repairing this equipment.
- Follow all applicable safety procedures required by your company, industry standards and government or other regulatory agencies.
- Install all electrical connections to local code.
- Use only electrical wire of sufficient gauge and insulation to handle the rated current demand. All wiring must meet local codes.
- Route electrical wiring along a protected path. Make sure they will not be damaged by moving equipment.
- Protect components from damage, wear, and harsh environment conditions.
- Allow ample room for maintenance, panel accessibility, and cover removal.
- Protect equipment with safety devices as specified by applicable safety regulations
- If safety devices must be removed for installation, install them immediately after the work is completed and check them for proper functioning prior to returning power to the circuit.

Failure to follow this instruction can result in serious injury or equipment damage

Additional Reference Materials



Important Information

- IEC - International Standards and Conformity Assessment for all electrical, electronic and related technologies.
- IEC 60364 - Electrical Installations in Buildings.
- FAA Advisory: AC 150/5340-26 (current edition), Maintenance of Airport Visual Aid Facilities.
- Maintenance personnel must refer to the maintenance procedure described in the ICAO Airport Services Manual, Part 9.
- ANSI/NFPA 79, Electrical Standards for Metalworking Machine Tools.
- National and local electrical codes and standards.

1.1.2 Intended Use



CAUTION

Use this equipment as intended by the manufacturer

This equipment is designed to perform a specific function, do not use this equipment for other purposes

- Using this equipment in ways other than described in this manual may result in personal injury, death or property and equipment damage. Use this equipment only as described in this manual.

Failure to follow this instruction can result in serious injury or equipment damage

1.1.3 Material Handling Precautions: Storage



CAUTION

Improper Storage

Store this equipment properly

- If equipment is to be stored prior to installation, it must be protected from the weather and kept free of condensation and dust.

Failure to follow this instruction can result in equipment damage

1.1.4 Operation Safety



CAUTION

Improper Operation

Do Not Operate this equipment other than as specified by the manufacturer

- Only qualified personnel, physically capable of operating the equipment and with no impairments in their judgment or reaction times, should operate this equipment.
- Read all system component manuals before operating this equipment. A thorough understanding of system components and their operation will help you operate the system safely and efficiently.
- Before starting this equipment, check all safety interlocks, fire-detection systems, and protective devices such as panels and covers. Make sure all devices are fully functional. Do not operate the system if these devices are not working properly. Do not deactivate or bypass automatic safety interlocks or locked-out electrical disconnects or pneumatic valves.
- Protect equipment with safety devices as specified by applicable safety regulations.
- If safety devices must be removed for installation, install them immediately after the work is completed and check them for proper functioning.
- Route electrical wiring along a protected path. Make sure they will not be damaged by moving equipment.
- Never operate equipment with a known malfunction.
- Do not attempt to operate or service electrical equipment if standing water is present.
- Use this equipment only in the environments for which it is rated. Do not operate this equipment in humid, flammable, or explosive environments unless it has been rated for safe operation in these environments.
- Never touch exposed electrical connections on equipment while the power is ON.

Failure to follow these instructions can result in equipment damage

1.1.5 Maintenance Safety



DANGER

Electric Shock Hazard

This equipment may contain electrostatic devices

- Do not operate a system that contains malfunctioning components. If a component malfunctions, turn the system OFF immediately.
- Disconnect and lock out electrical power.
- Allow only qualified personnel to make repairs. Repair or replace the malfunctioning component according to instructions provided in its manual.

Failure to follow these instructions can result in death or equipment damage

1.1.6 Material Handling Precautions: Fasteners



DANGER

Foreign Object Damage - FOD

This equipment may contain fasteners that may come loose - torque properly.

- Only use fasteners of the same type as the one originally supplied with the equipment.
- Use of incorrect combination of gaskets, bolts and nuts can create severe damages to the product installation and create safety risk .
- You need to know what base the light fixture will be installed in, in order to chose the correct gasket, bolts and nuts.
- Bolt type, length, and torque value are determined by type of base, height of spacers used, and clamp force required in FAA Engineering Brief No 83 (latest revision).
- Due to the risk of bolts vibrating loose, do not use any type of washer with the fixing bolts (such as split lock washers) other than an anti-vibration washer. Anti-vibration washers as defined in FAA EB 83 (latest edition) must be used. For installations other than FAA, use the base can manufacturer's recommendations.
- Always tighten the fasteners to the recommended torque. Use a calibrated torque wrench and apply the recommended adhesive type.
- Obey the instructions of the adhesives necessary for the fasteners.

Failure to follow these warnings may cause the fasteners to loosen, damage the equipment, potentially to loosen the equipment. This can lead to a highly dangerous situation of FOD, with potential lethal consequences.



Note

To minimize the risk of errors, the ADB SAFEGATE Sales Representative will have information on which gasket goes with which base. This information is also provided in the product Data sheets, the User Manuals and the Spare Part Lists.



CAUTION

Use of incorrect combination of gaskets, bolts and nuts can create severe damages to the product installation and create multiple safety risks.

To obtain a safe and watertight installation the O-ring and retaining bolt stated in the document must be used.

You need to know what base the light fixture will be installed in, in order to choose the correct gasket, bolts and nuts.

Failure to follow these cautions can result in equipment damage or aircraft FOD.

1.1.7 Material Handling Precautions, ESD



CAUTION

Electrostatic Sensitive Devices

This equipment may contain electrostatic devices

- Protect from electrostatic discharge.
- Electronic modules and components should be touched only when this is unavoidable e.g. soldering, replacement.
- Before touching any component of the cabinet you shall bring your body to the same potential as the cabinet by touching a conductive earthed part of the cabinet.
- Electronic modules or components must not be brought in contact with highly insulating materials such as plastic sheets, synthetic fiber clothing. They must be laid down on conductive surfaces.
- The tip of the soldering iron must be grounded.
- Electronic modules and components must be stored and transported in conductive packing.

Failure to follow this instruction can result in equipment damage

2.0 About this Manual

This document includes AXON runway inset light fixture information with a focus on safety, installation and maintenance procedures.

For more information, see www.adbsafegate.com.



Note

It is very important to read this document before any work is started.

This manual covers the following 12-inch and 8-inch fixtures:

- Runway Centerline L-850A(L) (RC)
- Runway Touchdown Zone L-850B(L) (RZ)
- Runway Edge L-850C(L) (RE)
- FAA Threshold and Threshold/End L-850D(L) (RT)
- FAA Runway End L-850D(L) (RN)
- L-850T(L) Runway Takeoff/Hold Light (TH)
- Stopway (SW)
- Runway Guard Light (RG)

2.1 How to work with the Manual

- Familiarize yourself with the structure and content.
- Carry out the actions completely and in the given sequence.

2.2 Abbreviations and Terms

This document may include the abbreviations and terms listed below.

Abbreviation and term	Description
CAA	Civil Aviation Authority
CCR	Constant Current Regulator
FAA	Federal Aviation Administration
ICAO	International Civil Aviation Organization
IEC	International Electrotechnical Committee
ILCMS	Individual Light Control and Monitoring System
LED	Light Emitting Diode
NATO	North Atlantic Treaty Organization
STAC	Service Technique de l'Aviation Civile (France)
STANAG	Standardization Agreement (NATO)

3.0 Introduction

The all-in-one solution

The 12-inch and 8-inch range is a bi- or unidirectional low protrusion light-emitting diode (LED) inset light fixture, available in multiple versions:

Non-MON	Basic operation providing power only
MON (Fail-open)	A LED light fixture with integrated fail open technology with CCR monitoring compatibility
EQ	Fixture with integrated ILCMS remote utilizing orthogonal frequency-division multiplexing (OFDM) technology providing superior communication interfacing with LINC 360 System.



NOTICE

All our Axon R-series light fixtures are equipped with failed LED detection monitoring as required by FAA Engineering Brief 67.

Figure 1: 12-inch and 8-inch Fixtures



Note

EQ light fixtures are not fail-open light fixtures. The monitoring as well as the control functionality is handled by the ILCMS system.

3.1 Product Information

Compliance and Standards

Compliance	Description	Application:	RC-RZ	RE 45 m	RG	RN-RT FAA
		Reference DS-XXXX:	5040	5041	5043	5044
FAA	AC 150/5345-46 and the FAA Engineering Brief No. 67		X	X	X	X
ICAO	Annex 14 Volume 1		X	X	X	
EASA	CS-ADR-DSN		X	X	X	
Australia	MOS 139		X	X	X	
Canada	TP 312		X	X	X	
IEC	61827		X	X	X	X
NATO	STANAG 3316		X	X	X	
STAC	PRO/STAC/SE/VIS		X	X	X	
UK	CAP 168		X			
CE			X	X	X	X

Compliance	Description	Application:	SW 45 m ICAO	RS/TS FAA	RS/TS ICAO
		Reference DS-XXXX:	5047	5070	5093
FAA	AC 150/5345-46 and the FAA Engineering Brief No. 67		X		X
ICAO	Annex 14 Volume 1		X	X	
EASA	CS-ADR-DSN		X		
Australia	MOS 139		X	X	
Canada	TP 312		X		
IEC	61827		X		
NATO	STANAG 3316		X		
STAC	PRO/STAC/SE/VIS		X		
UK	CAP 168				
CE			X	X	X

Uses RC-RZ

ICAO

- Runway centerline
- Touchdown zone

FAA

- L-850A(L) Runway centerline
- L-850B(L) Touchdown zone

Uses RE 45 m

ICAO

- Runway edge \leq 45 m width runway

FAA

- L-850C(L) Runway edge
- L-850C(L) Displaced threshold

Uses RG

ICAO

- Runway guard lights

FAA

- L-852G(L) Runway guard lights

Uses RN-RT FAA

FAA

- L-850D(L) Runway threshold
- L-850D(L) Runway end
- L-850D(L) Runway threshold/end (bidirectional green and red)

Uses SW 45 m ICAO

ICAO and MOS

- Stopway

Uses RS-TS FAA

FAA Runway Status Light (RWSL) Applications

- L-850T(L) THL Runway Takeoff/Hold Light
- L-850T(L) RIL Runway Intersection Light
- REL Runway Entry Light

Uses RS-TS ICAO

FAA Runway Status Light (RWSL) Applications

- L-850T(L) THL Runway Takeoff/Hold Light
- L-850T(L) RIL Runway Intersection Light

- REL Runway Entrance Light

Features and Benefits

Efficiency

- EQ has an integrated ILCMS for LINC 360 system providing high data capacity and resisting degradation from various types or radio effects to provide a superior communication platform
- Precision aimed optics enhancing photometric performance and complementing extended LED life
- Reduced bottom pan profile allowing for very shallow base can installation
- LEDs pulse width modulated (PWM) at 400 Hz optimizing LED performance and eliminating perceptible flicker to a moving human observer throughout the range of brightness steps
- Operates at all steps of constant current regulator technologies designed in compliance with IEC or FAA requirements
- Fully dimmable lights, conforming to the dimming curve of traditional halogen lights
- Low protrusion, high-intensity, Style 3 (< 6.35 mm) inset light fixtures
- No negative slope in front of the prisms

Sustainability

- Fully encapsulated all-in-one universal power supplies for Runway, Taxiway, Approach and Omni inset families
- Latest generation LEDs providing a long-lasting light source with high efficiency and low power consumption
- Reinforced top cover substantially exceeding standards to improve durability and longevity
- One single family of fixtures covering all runway, taxiway and approach applications
- IP68 rated enclosure designed for harsh environments; all fastenings are stainless steel
- Reinforced prism available as an option
- Compatible with existing infrastructure allowing for direct replacement of existing LED inset fixtures

Safety

- Improved mechanical design to strengthen and consolidate components, improving the customer maintenance experience
- Fail-open option for compatibility with legacy monitoring systems and optimization of advanced control/ monitoring systems
- Failed-LED Detection as required by Engineering Brief 67D
- Robust lightning protection complying with ANSI/IEEE C62.41-1991; Location Category C2 as required by FAA Eng. Brief 67. Category C2 is defined as a 1.2/50 μ S – 8/20 μ S combination wave, with a peak voltage of 10,000 V and a peak current of 5,000 A

Power Supply

- Non-Monitored — Power only
- Monitored — integrated Fail-open technology
- EQ with integrated ILCMS with OFDM technology for use with LINC 360 system

Maintenance and Installation

The light fixture can be installed on an 8-inch or 12-inch base. Gaskets are sold separately. Check what gasket and bolts to order depending on base and installation.

Operating Conditions

Operating temperature	-60 °C to +55 °C / -76 °F to +131 °F
Storage temperature	-60 °C to +80 °C / -76 °F to +176 °F
Humidity	Up to 100%

3.2 Dimensions and Weight

The weight and measurement [A] depends on version of the light fixture.

Version	Weight	Dimension
ICAO/FAA RC – RZ – RG ICAO RS FAA RS	3 kg / 6.6 lb (8 in)	203 mm / 8 in
ICAO/FAA RC – RZ – RE – RG ICAO SW – RN – RS – RT FAA RN – RS – RT	6.8 kg / 15 lb (12 in)	305 mm / 12 in

Figure 2: 12-inch and 8-inch Fixtures

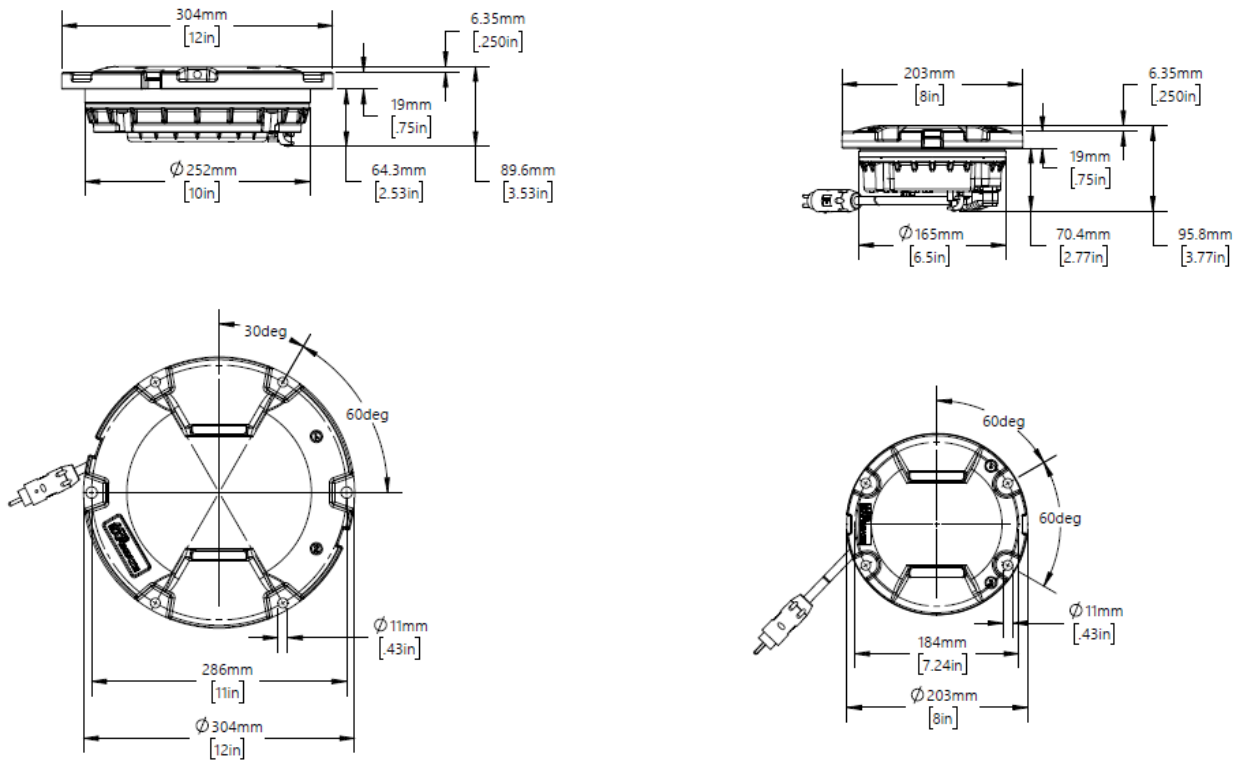

4.0 Installation

Install the inset light fixture in a base provided by ADB SAFEGATE as follows:



Note

If the inset light fixture is to be installed on another type of base or adapter ring not provided by ADB SAFEGATE, contact ADB SAFEGATE.



CAUTION

Use of incorrect combination of gaskets, bolts and nuts can create severe damages to the product installation and create multiple safety risks.

To obtain a safe and watertight installation the O-ring and retaining bolt stated in the document must be used.

You need to know what base the light fixture will be installed in, in order to choose the correct gasket, bolts and nuts.

4.1 Unpacking the Unit

To reduce the possibility of damaging the light assembly, unpack the light fixtures at the installation site. If damage to any equipment is noted, file a claim form with the carrier immediately.

When receiving the light fixture, open the box and verify that the characteristics of the light fixture correspond to the design requirements, such as type, color etc. When installing a light fixture where the control and monitoring function is to be activated at a later stage, make sure to register product information, such as PID/SN and position of the light fixture in, for example, a site documentation table. The information is required for remote activation and administration of control and monitoring functionality from a substation.

4.2 Tools required

The following tools are recommended for installation.

- One Box spanner 16/17 mm.
- One torque wrench with a 16/17 mm socket.
- Two large flat headed screwdrivers for lifting the light fixture.
- One T20 Torx key.
- One brush or cloth.



Note

Provided that the base intended to receive the light fixture has been properly installed, no other specific tool is required.

4.3 Installation

Install the inset light fixture in a base provided by ADB SAFEGATE as follows:



Note

If the inset light fixture is to be installed on another type of base or adapter ring not provided by ADB SAFEGATE, contact ADB SAFEGATE.



CAUTION

Use of incorrect combination of gaskets, bolts and nuts can create severe damages to the product installation and create multiple safety risks.

To obtain a safe and watertight installation the O-ring and retaining bolt stated in the document must be used.

You need to know what base the light fixture will be installed in, in order to choose the correct gasket, bolts and nuts.

4.3.1 Installation Overview

On a shallow base.

The 8" dia. base is secured in the pavement by means of resin. Correct positioning and leveling are obtained with a jig with sighting telescope. Wires between the light and the series transformer are installed either in saw cuts in the pavement filled with resin or in pipes in the lower concrete layers. Mounting on existing or new, larger diameter bases, is made possible by means of dedicated adapter rings.

Figure 3: Installation on 8" shallow base

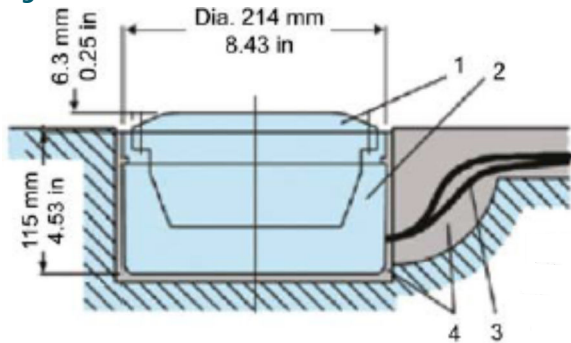

On a FAA L-868B size B steel base.

The 8" dia. light is mounted in an 8" to 12" dia. snow plow or adapter ring bolted onto the base. The 12" fixture is directly mounted without a separate ring. The bases are interconnected by means of conduits protecting the cables. See FAA AC 150/5340-30 for additional design guidance on deep base cans. The series transformer is installed under the light or in a separate pit. See data sheet A.05.120 or DS2012 for more information on base cans.

Figure 4: Diagram of the Fixture Installed in a 1-Piece Base Can

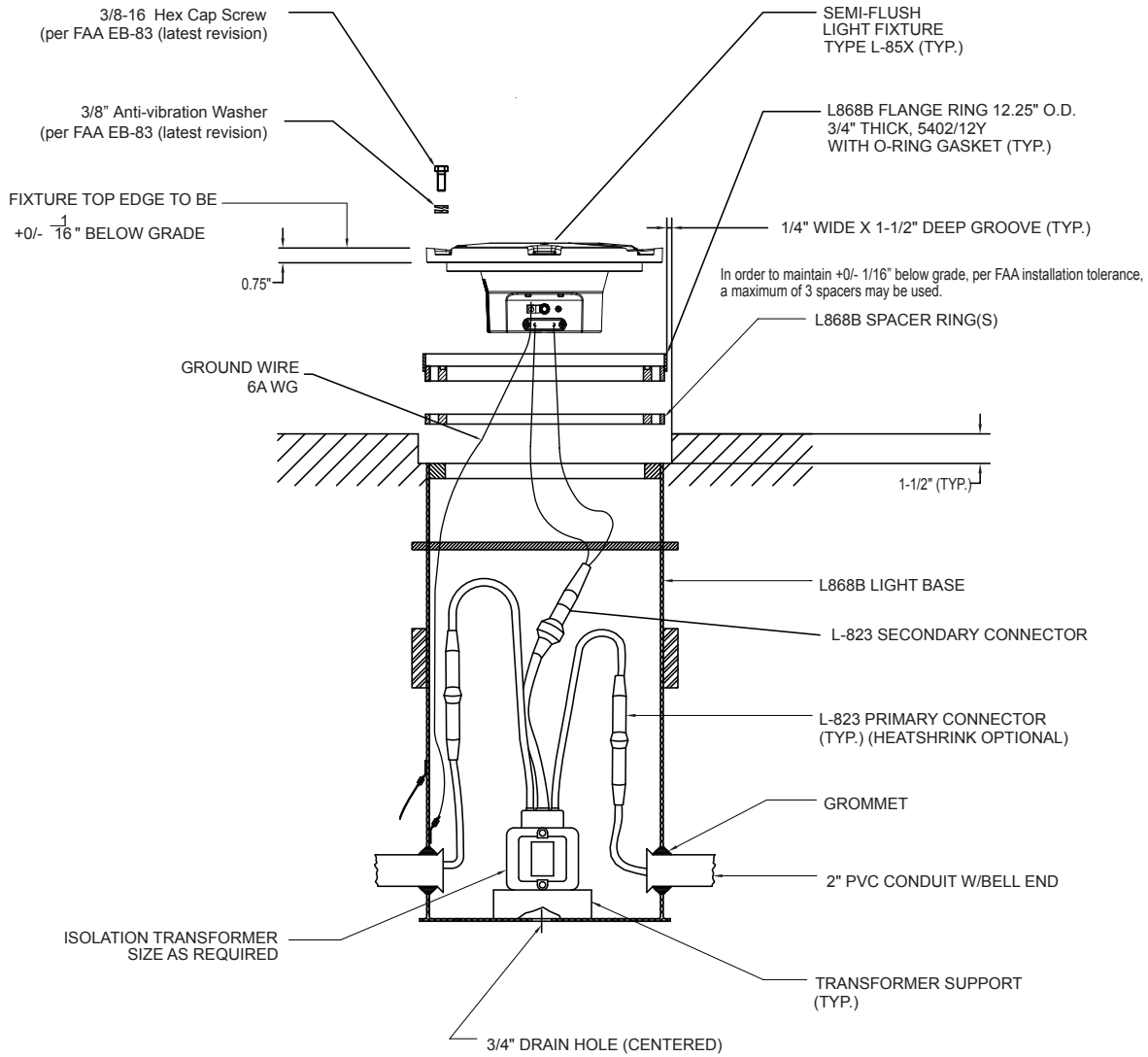

Note

Torque according to: FAA EB-83 (latest revision).

Figure 5: Anti-vibration washer example

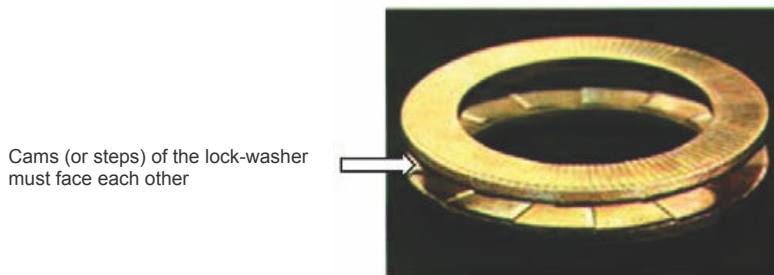



CAUTION

Per FAA AC 150/5340-30, Chapter 10, and FAA Engineering Brief No 83 (latest revision), it is extremely important that other types of washers, such as split washers, must not be used. Failure to use properly installed anti-vibration lock washers will cause mounting bolts to become loose. The cams (or steps) of each half of the lock washer must face each other.

4.3.2 Installation and Removal of the 12-inch Light Fixture



WARNING

Read the instructions in their entirety before starting installation.

This section provides instructions for installing the in-pavement lights. Refer to airport project plans and specifications for specific installation instructions. The installation must conform to the applicable sections of the National Electric Code and local codes.

Install the light fixture in a base, class 1, direct-mounted fixtures

Figure 6: 12-in shallow base, class 1, direct-mounted fixtures

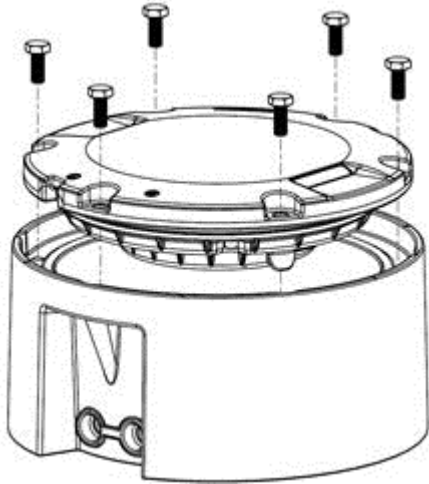

1. Carefully clean all contact surfaces of the light fixture and the base.
 2. Put the O-ring gasket in the gasket track on the base.
-



Note

Not for class 2.

3. Connect the connector(s) of the light fixture to the base supply cable(s). Check that the sides 1 and 2 are connected to corresponding circuit if two connectors are used.
 4. Align the position of the light fixture in one line with the holes.
 5. Mount light fixture to the base.
-



Note

Make sure the secondary cables are below the light and not quenched between the light and base.

6. For an installation on bases, use a torque limiting box spanner of 16/17 mm, install and tighten the two, four or six fixing bolts (version-dependent) or nuts to a torque value according to specification, see [INTEROPERABILITY](#). For other base manufacturers, refer to their specifications.
-



Note

Do not use high speed for tightening, the recommended speed is 10 - 40 rpm. Do not use an impact driver/wrench.

7. After installation, make sure that each light fixture functions properly.
8. In order to bond the light fixture to ground, use a ground lug or grounding screw (torque 2.5 Nm) to attach the braided ground strap or ground wire to the grounding point on the light fixture. The grounding point is indicated by a grounding symbol and located on the bottom side.

Remove the fitting from the base



CAUTION

Fall- and trip hazard! When a light fixture has been removed, the base must be fitted with a cover designed for this purpose or with a spare light fixture.

1. Remove the light fixture from the base using two large flat blade screwdrivers.
2. Disconnect the secondary supply connector.
3. Remove and check the gasket (O-ring or labyrinth).



Note

It is recommended to change the gasket, lock nuts or bolts each time the light fixture is removed or dismantled from the base. For more information, see [INTEROPERABILITY](#).



CAUTION

Use of incorrect combination of gaskets, bolts and nuts can create severe damages to the product installation and create multiple safety risks.

Make sure to know what base the light fixture will be installed in, in order to choose the correct gasket, bolts and nuts. Failure to follow these cautions can result in equipment damage or aircraft FOD. For more information, see [INTEROPERABILITY](#).

4.4 Toe-in

Toe-in of light fixtures can be achieved in two ways:

1. By installing the light fixture in runway/taxiway parallel bases and use light fixtures with built in toe-in.
2. By installing the light fixture in bases installed at an angle relative the runway/taxiway and use light fixtures with no built in toe-in.

If bases which are installed at an angle are used, provided that they are installed correctly, straight light fixtures, i.e. with no toe-in, should be used.

The following chapter only regards the case where light fixtures are installed in runway/taxiway parallel bases, i.e. where no toe-in is achieved by angled bases.

There are three major categories regarding the toe-in in light fixtures:

Straight light fixtures	These light fixtures have a straight light beam
Light fixtures with optical toe-in	These light fixtures have a reflector that reflects the light beam at an appropriate angle
Light fixtures with mechanical toe-in	These light fixtures are installed at an angle with in its base due to the hole pattern for the base screws. This results in an angled light beam relative to the runway/taxiway.

Figure 7: Toe-in

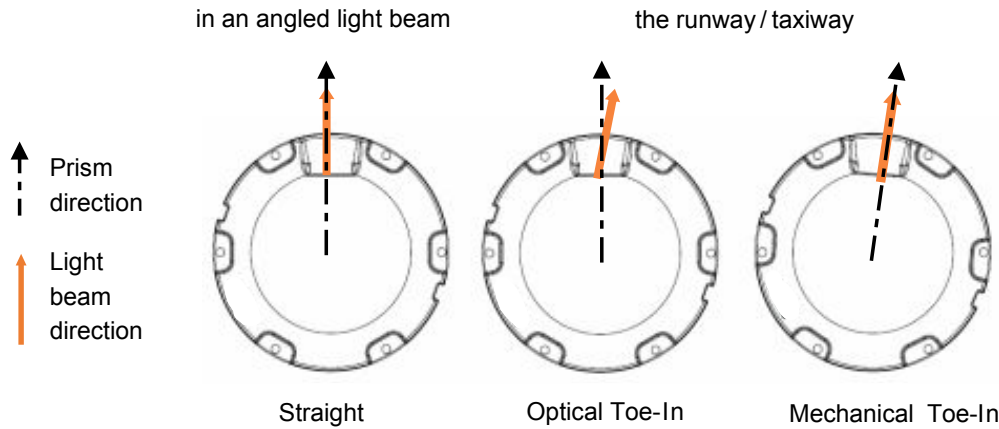

The table below shows a summary of the light fixture types and their toe-in properties.

Light fixture	Toe-in options	Toe-in type
L-850A(L) - Runway Centerline (RC-I)	Straight	N/A
L-850B(L) - Runway Touchdown Zone (RZ-I)	Straight or Toe-in $\pm 4^\circ$	Mechanical
L-850C(L) - Runway Edge (RE-I)	Toe-in to centerline	Optical
L-850D(L) & ICAO - Runway Threshold (RT-I)	Straight or Toe-in $\pm 3.5^\circ$	Optical
L-850D(L) - Runway End (RN-I)	Straight	N/A
L-850D(L) & ICAO - Runway Threshold End (RTN-I)¹	Straight or Toe-in $\pm 3.5^\circ$	Optical
L-850T(L) - Runway Status, Takeoff, Runway Intersection Light (RS-I)	Straight	N/A
Approach Centerline (AC-I)	Straight	N/A
Approach Cross Bar (AC-I)	Straight or Toe-in $\pm 2^\circ$	Mechanical
Approach Siderow (AS-I)	Straight or Toe-in $\pm 2^\circ$	Mechanical
Runway Threshold Wingbar (RW-I)	Straight or Toe-in $\pm 2^\circ$	Mechanical
Rapid Exit Taxiway Indicator (RX-I)	Straight	N/A
Stopway (SW-I)	Toe-in to centerline	Optical
L-852C(L) -Taxiway Centerline Narrow (TC-I)	Straight	N/A
L-852K(L) -Taxiway Centerline Curve (TC-I)	$\pm 15.75^\circ$	Optical
Taxiway Centerline Wide (TC-I)	Straight	N/A
L-852D(L) -Taxiway Centerline/Lead-On (TC-I)	Straight	N/A
L-852S(L) & ICAO Stop Bar (SB-I)	Straight or Toe-in $\pm 15.75^\circ$	Optical

Notes

¹ Toe-in only affects the green threshold side.

4.5 Light Emission Directions

4.5.1 Definition of Light Emission Directions

Light fixtures that have a toe-in are marked with an arrow to ensure a correct installation with regard towards the toe-in. The light fixtures should be installed with the arrow pointing towards the centerline.

The color and direction of the emitted light is indicated with a painted line on the top cover in front of the prism. On angled lines the light beam is emitted in the direction of the line. Sides with a straight line have a straight light beam.

The bidirectional light fixtures are all marked with A and B direction on the top plate and also on the outside of the bottom cover. This is to help orienting the top during installation and to keep track of the color and toe-in of each side.

Figure 8: Light emission directions

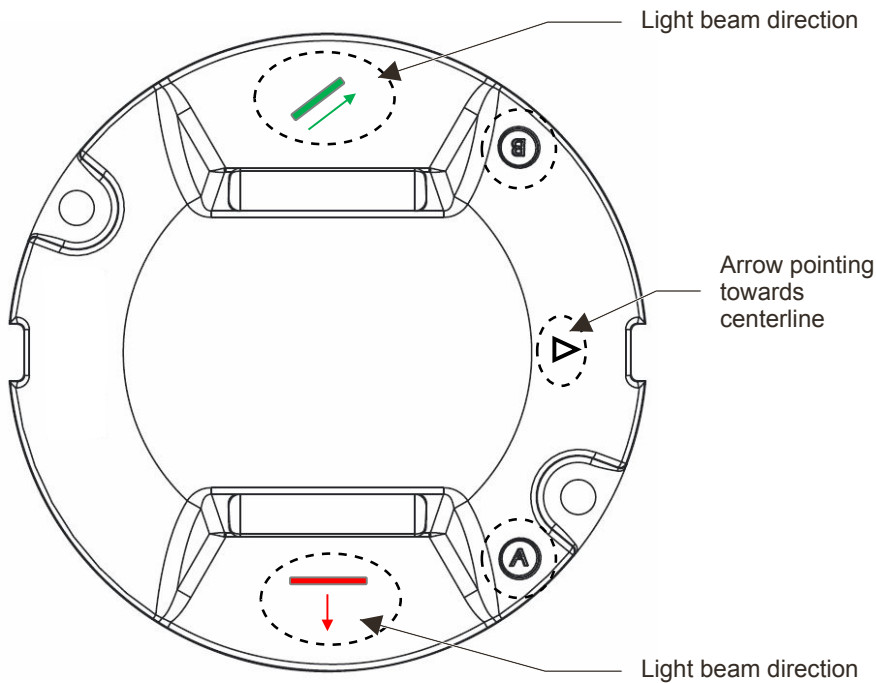

5.0 Maintenance

This section describes different steps for maintenance of the light fixture.

Before you start, make sure you have read and understand [Safety instructions](#).

Find out the location of the light unit that needs maintenance. If the purpose is to replace an existing light unit with new one, make sure that corresponding unit is available. Find the type information on the identification tag with details of name.

Spare parts are available, if required. For more information, see www.adbsafegate.com and the Spare Parts List document, or contact ADB SAFEGATE for assistance.



CAUTION

Use of incorrect combination of gaskets, bolts and nuts can create severe damages to the product installation and create multiple safety risks.

You need to know what base the light fixture will be installed in, in order to choose the correct gasket, bolts and nuts. Failure to follow these cautions can result in equipment damage or aircraft FOD.



CAUTION

When a light fixture has been removed from its base, the base must be either fitted with a cover or a spare light fixture put in its place. It is recommended that only authorized personnel disassemble fittings with prior agreement from ADB SAFEGATE.

5.1 Basic Maintenance Program

It is important to understand that even though a LED fixture requires substantially lower maintenance in regard to the replacement of the light bulbs, some parts of the light fixture remain the same and still require the same level of maintenance (prisms, top cover, bolts).

There are recommended maintenance tasks to ensure that the equipment is in correct operating condition.

Maintenance tasks

Weekly	<ul style="list-style-type: none"> • Visual inspection of the light fixture. • Removal of dust from external surfaces of the light fixture.
Monthly	<ul style="list-style-type: none"> • Check optical window for cleanliness, mechanical damage or moisture/condensation on the inside of the prism • Check for improper torque on mounting bolts. Re-torque if needed.
Yearly	<ul style="list-style-type: none"> • Detailed inspection of the light fixture • Check of the body resistance, check for mechanical damage (for example cracks around the prism windows). • Clean optical windows
Bi-yearly	<ul style="list-style-type: none"> • Check for presence of water in mounting support by unscrewing and lifting light fixture from base and check for water ingress and corrosion. Replace gasket between light fixture and base.
After snow removal	<ul style="list-style-type: none"> • Check for damaged light fixtures. Any damaged light fixtures should be replaced and brought in and properly investigated and repaired.

A daily function check is referred to in the document:

ICAO, Airport Services Manual Part 9, Airport Maintenance Practice and FAA AC 150/5340-26A, Maintenance of airport visual aids facilities.

Any issues found during maintenance tasks should be corrected accordingly and properly documented.

A proper asset management system such as ADB Safegate's ALIS can help to store/document data and can provide valuable information on local presiding conditions for preventive maintenance planning. This can then be used to minimize the need for reactive maintenance.



ALIS, ADB Safegate's new digital asset tracking, inspection and service solution, helps airports easily register airside assets, electronically schedule and track maintenance, and record maintenance and inspection tasks in compliance with ICAO and FAA standards.

Visit alis.adbsg.com.

5.2 Recommended Maintenance Program for optimal Service Life

Service Life and Inspection intervals

All products have an expected service life. Service life is the lifetime of the product and reaching the end means that it is no longer serviceable and should be replaced.

There are several key external factors that influences the service life of a product.

- Aircraft traffic movements
- Location on the airfield
- Maintenance
- Chemical usage

Air Traffic Movements (ATM)

The expected lifetime of a light fixture will be highly impacted by the traffic volume and the number of aircraft that are mechanically putting stress on the light fixtures. Airports with a higher traffic volume will have a light fixture with a shorter expected lifetime than an airport with a lower traffic volume.

The ATM can be divided into three categories for the recommendation of inspections as well as for the expected lifetime of a light fixture ^{*}.

- 0-100k movements/ year
- 100k-200k movements/ year
- >200k movements/ year

Location on the airfield

The expected lifetime of a light fixture is highly dependent on the location where it is installed on an airfield. Three different areas have been defined by color categorization that are exposed to different degree of mechanical impact. These three categories are used as a basis for the recommendation of inspections as well as for the expected lifetime of a light fixture.

- **RED** – Touch Down Area defined as 6m either side of the runway centerline for a distance starting 50m before the TDZ markings and extending to 200m beyond the TDZ markings as seen from the landing direction.
- **RED** – Rapid Exit Taxiway centerline lights from the runway centerline to 50m beyond the edge of the runway.
- **Amber** – All runway areas outside of the red areas. Also includes taxiway intersections for which more than 50% of the aircraft traffic turn more than 45 degrees.
- **Green** – Areas outside Red and Amber areas



NOTICE

It is recommended that there is a reliable means of recording the location history of fittings (similar to ADB Safegate ALIS) to ensure that the maximum duration in critical areas (RED) of the runway are not exceeded.

^{*} Based on ADB SAFEGATE's field experience and investigation made together with an independent consultant and airport.

Preventive maintenance

Preventive maintenance and inspections will help to prolong the service life of a light fixture. By finding issues (e. g., bad gaskets or broken prisms) at an early stage you can mitigate and fix issue before they cause more damage and reduce the cost of the repair. You can also increase the service life of a light fixture by rotating the installation location of light fixtures in critical areas.

Regular inspections and well-defined preventive maintenance planning will help to reduce the overall maintenance cost and reduce downtime from reactive maintenance tasks.

Figure 9: Preventive Maintenance

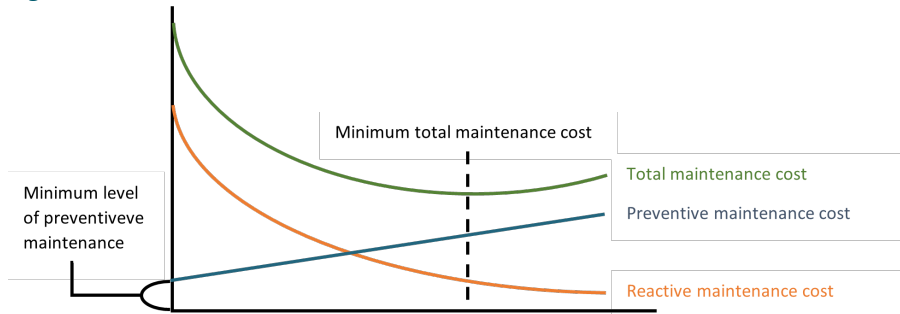

5.2.1 Recommendation

Based on the air traffic volume and location on the airfield, a matrix was created for recommended inspection intervals.

Figure 10: Visual Inspection Interval

Location	RED	Amber	Green
ATM			
0-100k movements	2 Months 1 Year	6 Months 3 Years	1 Year 3 Years
100k-200k movements	2 Months 1 Year	4 Months 2 Years	1 Year 3 Years
Above 200k movements	1 Months 6 Months	2 Months 1 Year	1 Year 3 Years

Inspection interval

Visual inspection: Visually inspect the light fixture and make sure that

- Prism is clean and no cracks are visible
- Gaskets are ok and are not deteriorating
- No moisture or condensation can be seen on the inside of the prism
- Corrosion on top cover, around the prism and bolts.
- Torquing of nuts/bolts are according to specification

Detailed Inspection: Includes visual inspection tasks and additionally the following tasks

- Unbolt the light fixture and lift it from the base for the detailed inspection
- Check for water ingress (watertight installation) and corrosion on light fixture and base (especially around the mating surfaces)
- For deep base installation (L-868) check for water ingress, if more than 6 inches please have it removed.
- Inspect light and base for damage
- Replace gasket between light fixture and base

NOTICE

We recommend any maintenance work that requires the light fixture to be opened to be done back in the dedicated maintenance area.

- We recommend that inspection intervals are halved for aging units that have reached more than 75 % of their expected lifetime.
- We recommend that AGL in critical areas are rotated.
- To achieve a proper location rotation and individual asset, data needs to be recorded.
- To relax the recommended frequencies of some maintenance tasks i.e. torque management, data is needed for justification.
- Policies have a direct link with the age of the AGL and should also be tracked and recorded.

Below is the recommended service life. With a proper asset management (ALIS or similar) and data capturing strategy, the below guidelines could be extended or shortened as deemed necessary via presiding local conditions.

Expected service life (only critical areas defined)

• RED Zone -, ATM < 100k	Service Life 15 years
• RED Zone -, ATM > 100k < 200K	Service Life 10 years
• RED Zone -, ATM > 200k	Service Life 7 years



Note

Contact to your local sales representative if you have any questions or would require some assistance to go through local conditions and see how we can help establish a well-defined maintenance planning to optimize the expected service life of your investment.

5.3 Workshop Maintenance



CAUTION

Before you start, make sure you have read and understand [Safety instructions](#).

The following standard tools and accessories are required for maintenance of the unit:

- One angled socket spanner of 16 or 17 mm ¹
 - One Torque limiting spanner with 16 or 17 mm socket ¹
 - One hexagonal key (Allen key) of 3, 4, and 5 mm
 - Torx 10, 20, 25, and 30
 - Two large flat blade screwdrivers
 - Silicone grease
 - CC-Patron grease
 - One brush or cloth
 - Non-alcohol based cleaner
-



Note

A compressor, or a manual car tire pump, equipped with a manometer is required to check the light fixture for water-tightness.

Design may differ from picture depending on application. Please follow described work flow and torque level specified as they are generic.

The workshop maintenance refers to following:

1. Replace a light fixture
2. Check the light fixture for water-tightness
3. Replace a light engine
4. Replace a prism and its gasket
5. Replace the bottom cover and converter
6. Reset the fail-open converter

5.3.1 Opening a Light Fixture — disconnecting the Bottom Pan from the Top Cover

Tools to be used:

- Variable-speed/Torque drill driver with T25 bit (8-inch fixtures) and T30 (12-inch fixtures) bit options

¹ Depending on type and size of nuts and bolts



NOTICE

Do not use an Impact driver.

- Flat-head screwdriver

1. Place the light fixture upside down.
2. Loosen the Pressure Release Screw.

Figure 11: Loosening Pressure Release Screw

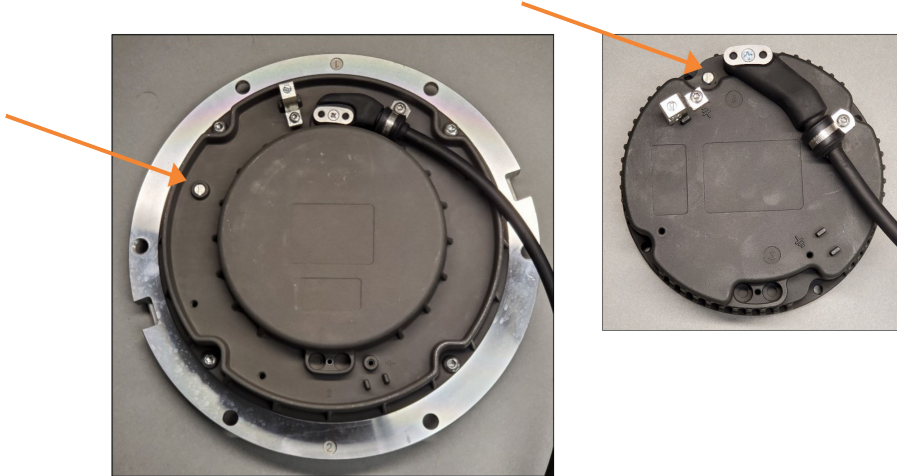

3. Unscrew the fixation screws (4 pcs, keeping the bottom cover attached to top cover). Make sure you **dispose the old screws** and use new screws.
4. Lift the Bottom Pan without damaging the connecting wires.



CAUTION

Make sure you do not damage the cables when opening the light fixture.

5. Disconnect the wires:
 - a. Pull carefully to disconnect the wires between the converter and the light engine.
 - b. Pull carefully to disconnect the wires between the converter and the heater kit(s), if the heater kit is in place.
6. Remove the gasket between the Top Cover Assembly and the Inner Pan Assembly. Make sure you **dispose the old gasket** and use a new gasket.

5.3.2 Close a Light Fixture — connect the Bottom Pan to the Top Cover

Tools to be used:

- Screwdriver T25 bit
- Flat-head screwdriver

1. Clean all the contact surfaces of the light fixture and of the housing carefully.
2. Press the gasket (located between top cover and inner pan) into the O-ring Groove. Make sure the gasket placed correctly.

Important

The O-ring Gasket must always be changed when the fixture is being disassembled.

Figure 12: Gasket Placement

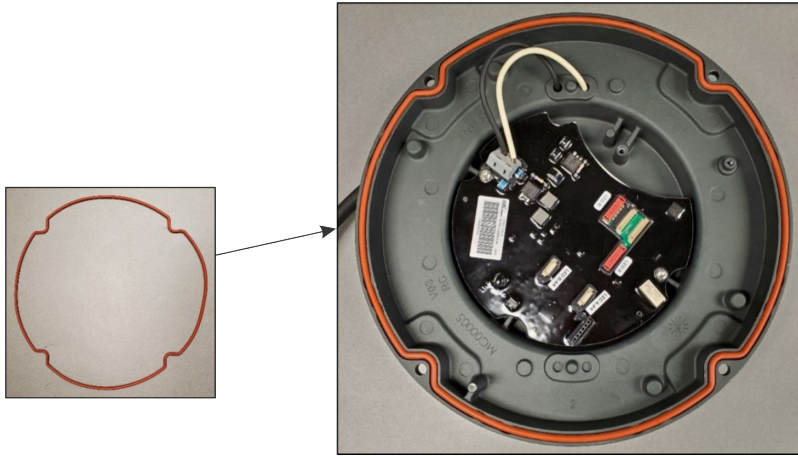

3. Connect the wires:
 - a. Press carefully to connect the wires lead in from the light engine on the converter.
 - b. Press carefully to connect the wires lead in from the light engine on the converter, if the heater kit is in place.
 4. Put the Top Cover onto the Bottom Pan.
Make sure the poke-yoke (alignment pin) is in the placed correctly.
-

Important

Do not pinch the wires or the gasket.

Figure 13: Top cover placement

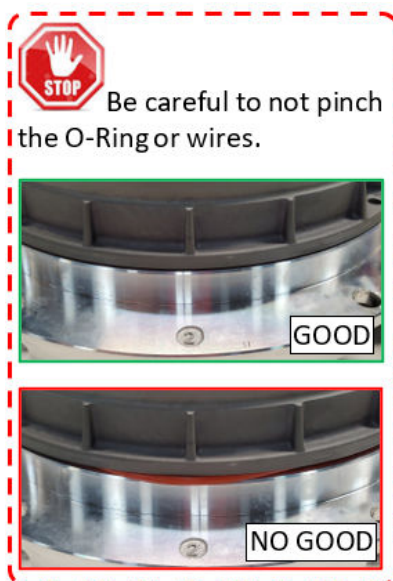

5. Put the light fixture on a surface with the top cover facing down.
-

6. Torque:
 - a. Use new fixation screws to torque in star pattern at 53 in-lbs (6 Nm) for 12-inch light or 31 in-lbs (3.5 Nm) for 8-inch lights.
 - b. Retorque the screws in star pattern at 53 in-lbs (6 Nm) for 12-inch light or 31 in-lbs (3.5 Nm) for 8-inch lights.
7. Follow the water-tightness test procedure.

i Note
Refer to the [Check the Light Fixture for Water-tightness](#) section.

5.3.3 Replace the Wire Harnesses

Tools to be used:

- Screwdriver T20 bit

1. Open the light.

i Note
Refer to the [Open and close a 12-inch Fixture](#) section.

2. Disconnect the old wire harnesses.
Make sure you **dispose the old wire harnesses** and use new wire harnesses.

Figure 14: Dispose old wire harnesses

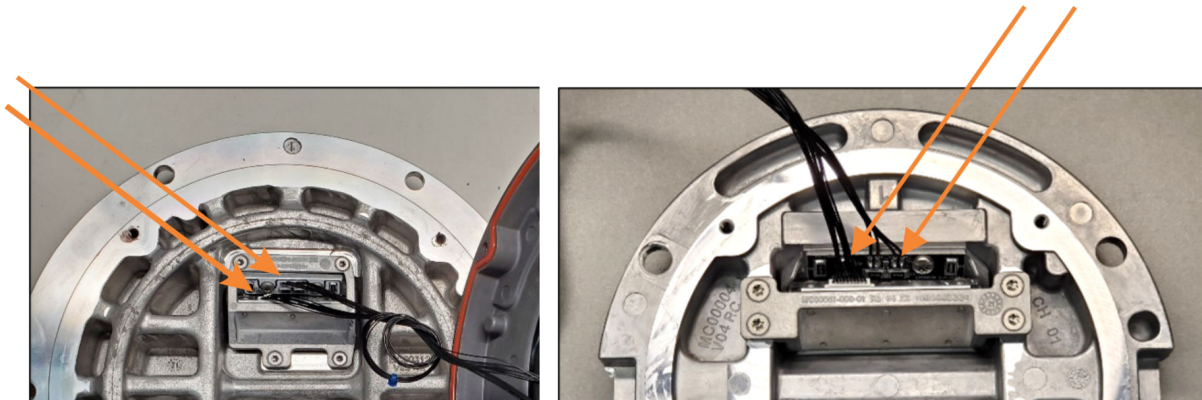

3. Connect the new wire harnesses.
Make sure the direction of the connector is correct to avoid damaged pins.
4. Close the light.

i Note
Refer to the [Open and close an 8-inch Fixture](#) section.

5.3.4 Replace the Light Engine Assembly

Tools to be used:

- Screwdriver T25 bit

1. Open the light.

Note Refer to the [Open and close a 12-inch Fixture](#) section.

2. Remove the Light engine(s) (4 pieces M4 screws per light engine assembly).
Make sure you **dispose the old screws, light engine(s), and wire harness(es)**, and the new material.

Figure 15: Removal of light engine(s) assembly

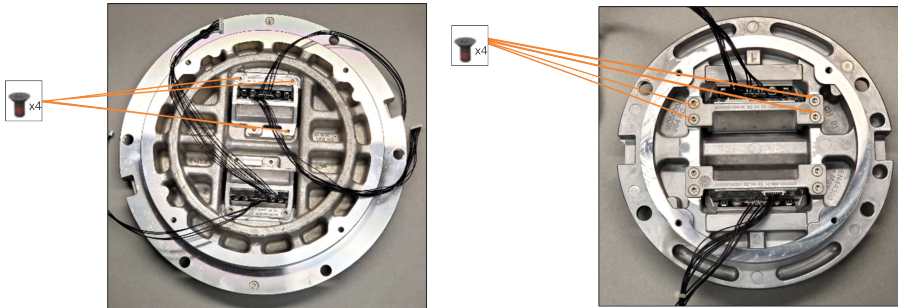

3. Mount the new light engine(s) with the wire harnesses attached.
4. Use new screws to attach the light engine in star pattern at 26 inch-pound (3.0 Nm).
5. Close the light.

Note Refer to the [Open and close an 8-inch Fixture](#) section.

5.3.5 Replace the Prism and its Gasket

Tools to be used:

- Screwdriver T25 bit

1. Open the light.

Note Refer to the [Open and close a 12-inch Fixture](#) section.

2. Remove the Light engine assembly (4 M4 screws per light engine assembly).
Make sure you **dispose the old screws** and use new screws.

Figure 16: Removal of light engine(s) assembly

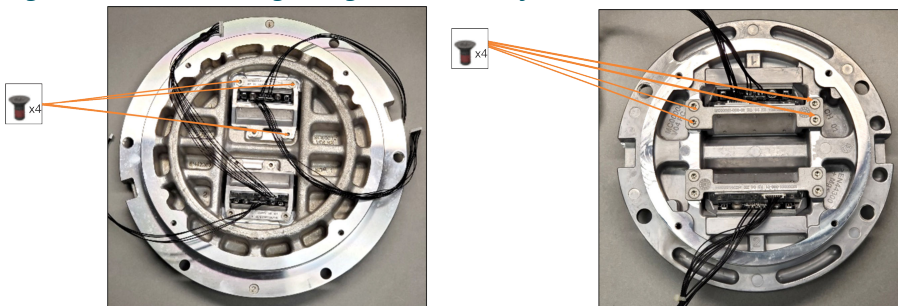

- Remove the Prism-keeper Plate and Prism-protection Gap Pad (4xM4x10 and 2xM4x8).

Figure 17: Removal of the prism-keeper plate and prism-protection gap pad

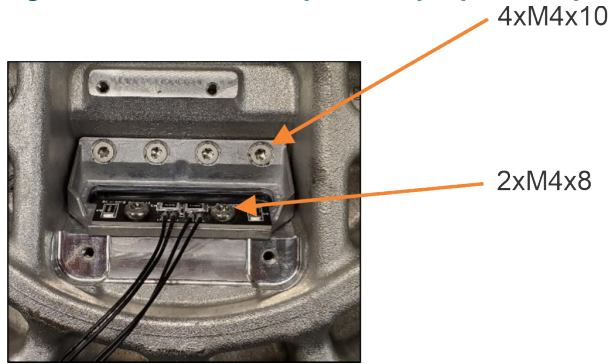

- Remove the prism the prism gasket by pushing from outside.
Make sure you **dispose the old prisms and gaskets** and the new material.
- Install the new sock seal and mount the new prism gasket into the top cover.

Important

Make sure the wider slant is oriented towards the center of the fixture.

- Apply some glass cleaner on the outside of sock seal.
- Press the prism assembly into the window of the top cover with a rocking motion.
- Use pressure to set the prism into the top cover.
- Clean the prism with a clean rag or a wipe.
- Place the Prism Protection Gap Pad on top of the prism.

Figure 18: Prism protection gap pad placement

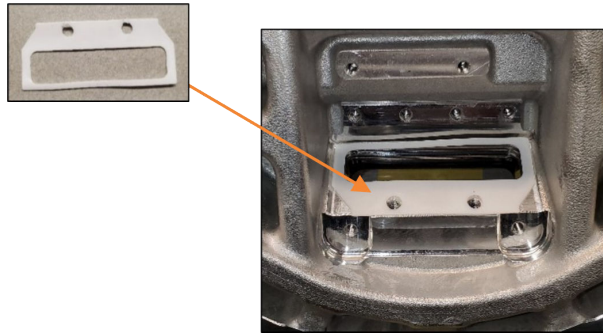

- Install the Prism-keeper Plate into the top cover with 2 M4x10 screws (26 in-lbs/3 Nm) to the "top" of the Prism-keeper Plate.

The heater must be installed under the screws, if the heater is included.

Figure 19: Prism-keeper plate installation into the top cover

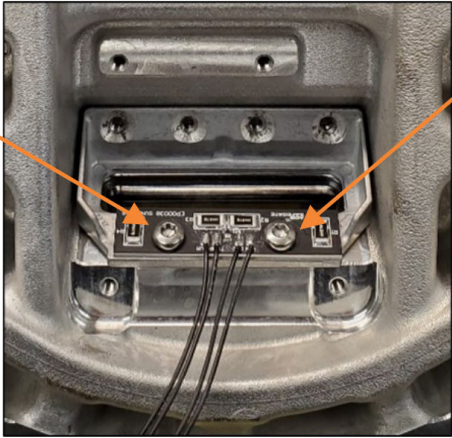

12. Finish the mounting procedure for the Prism-keeper Plate with 4 M4x8 screws at 26 in-lbs (3 Nm) to the “bottom” of the prism keeper plate.
Make sure you tighten the screws in the correct order (refer to the image below).

Figure 20: Mounting procedure

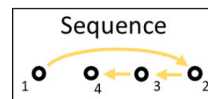
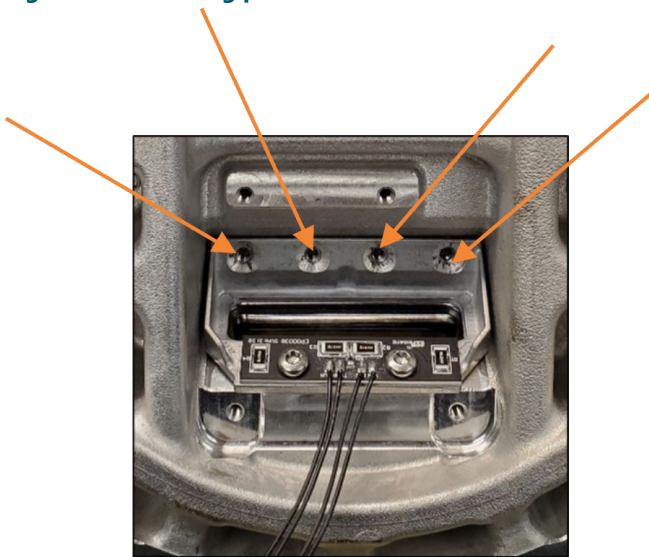

13. Mount the Light Engine Assembly onto the top cover with 4 new M4x10 screws at 26 in-lbs (3 Nm).

Important

Make sure you mount the Light Engine Assembly on the correct side of the top cover, with the correct color and toe-in (refer to the image below).

Figure 21: Light engine assembly mounting procedure

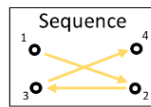
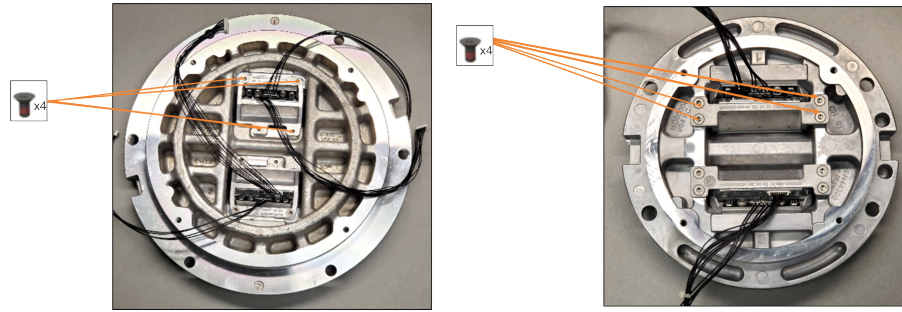

14. Close the light.



Note

Refer to the [Open and close an 8-inch Fixture](#) section.

5.3.6 Replace the Top Cover Assembly

Tools to be used:

- Screwdriver T25 bit
- Flat-head screwdriver

1. Open the light.

Note Refer to the [Open and close a 12-inch Fixture](#) section.

2. Remove the Light Engine(s) (4 M4 screws per light engine assembly.)
Make sure you **dispose the old screws and the old top cover** and use the new material.

Figure 22: Dispose old screws and old top cover

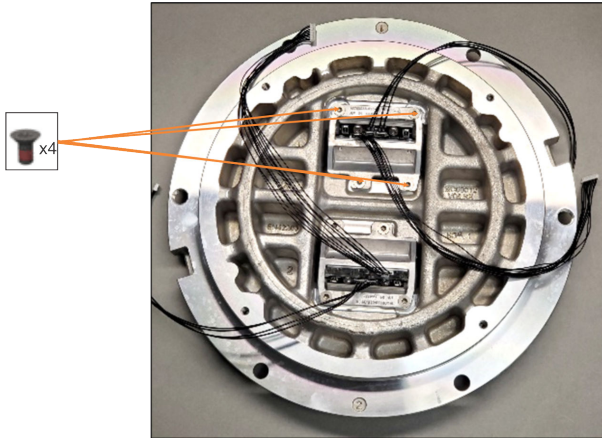

3. Replace the old top cover with new top cover assembly.
4. Mount the light engine(s) into the new top cover assembly.
5. Use 4 new M4x10 screws to attach the light engine in star pattern at 26 in-lbs (3 Nm).

Figure 23: Sequence

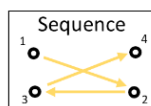

6. Close the light.

Note Refer to the [Open and close an 8-inch Fixture](#) section.

5.3.7 Replace the Bottom Cover Assembly

Tools to be used:

- Screwdriver T25 bit
- Flat-head screwdriver

1. Open the light.

i Note Refer to the [Open and close a 12-inch Fixture](#) section.

Make sure you **dispose the old bottom cover assembly** and use the new assembly.

2. Close the light.

i Note Refer to the [Open and close an 8-inch Fixture](#) section.

5.3.8 Replace the secondary Cable — SJO cord set

Figure 24: Secondary cable replacement



Tools to be used:

- Screwdriver T25 bit
- Flat-head screwdriver
- Small flat head screwdriver

1. Open the light.



Note

Refer to the [Open and close a 12-inch Fixture](#) section.

2. Disconnect the cable:

- a. Disconnect the secondary cable from the converter by placing a small flat-head screwdriver into the opening located at the other side of the secondary wire, and
- b. Release the cable by prying the screwdriver on the cable release opening.

Figure 25: Disconnecting secondary cable

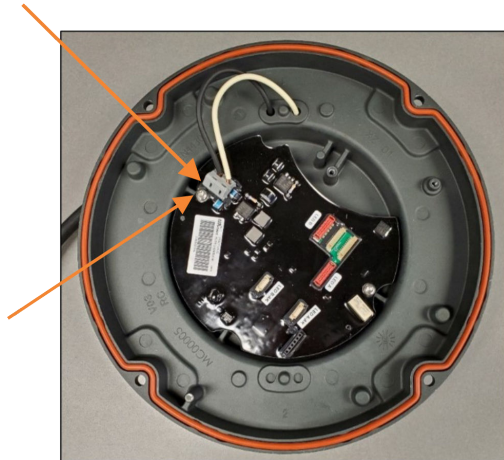

3. 4. Unscrew the Cord-set-retainer Disc Bolt.

Make sure you **dispose the old bolt and Cord-set-retainer disc** and use the new material.

Figure 26: Dispose old bolt and cord-set-retainer disc

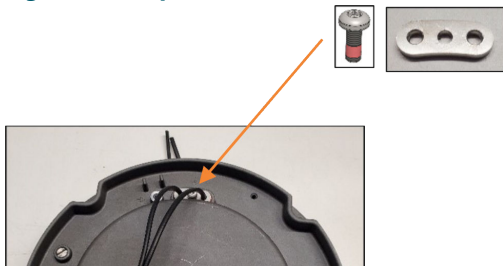

4. Unscrew the cable clamp.

Make sure you dispose **the old bolt, washer and lock washer** and use the new material.

Figure 27: Dispose old bolt, washer and lock washer

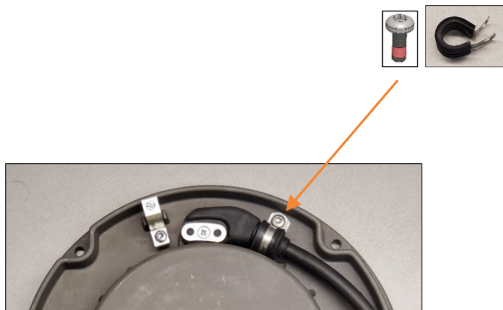

5. Remove the secondary cable.

Make sure you dispose **the old secondary cable** and use the new secondary cable.

6. Remove the old cable gland gaskets.

7. Install the new cable gland gaskets.

Figure 28: New cable gland gasket installation

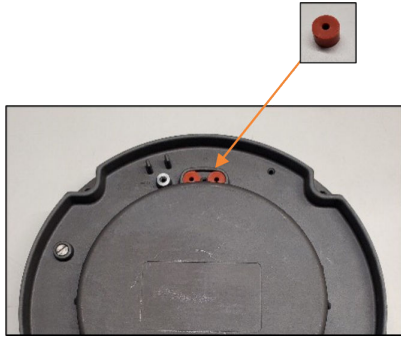

8. Install the new Cord-set-retainer Disc (M4x10) into the Bottom Cover. Make sure the **Cord-set-retainer Disc** sits loosely in the Bottom Cover.

Figure 29: Loosen the cord-set-retainer disc in the bottom cover

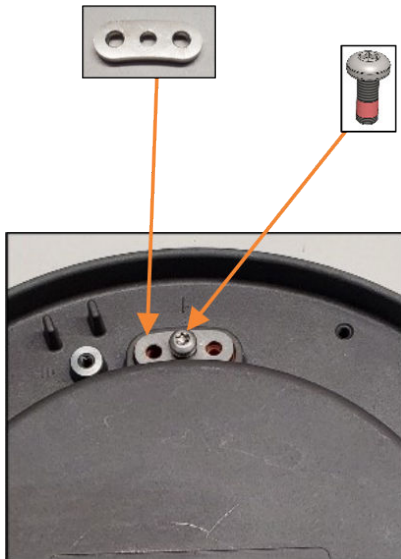

9. Installation:

- a. Install cord set into the Bottom Over using the cord set.
- b. Pull the cable through into the inside of the Bottom Cover. Make sure the cable is on the inside of the Bottom Cover.
- c. Mount the Retainer Disc onto the cable.
- d. Tighten the screw at 26 in-lbs (3 Nm).

- e. Loop the clamp using a new screw, lockwasher and flatwasher.
- f. Tighten the new screw, lockwasher and flatwasher at 26 in-lbs (3 Nm).

Figure 30: Installation steps overview

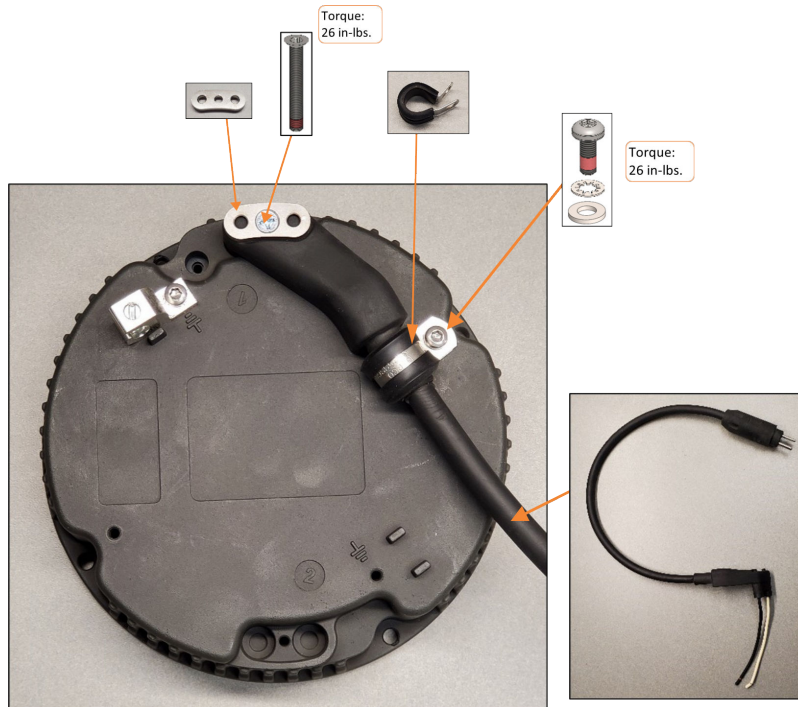

10. Locking:

- a. Lock the secondary cables leading to the converter by opening the cable holes prying a thin screwdriver on the cable release opening and mounting the wires in place and
- b. Lock the cables by releasing screwdriver from the opening.

Figure 31: Locking secondary cables

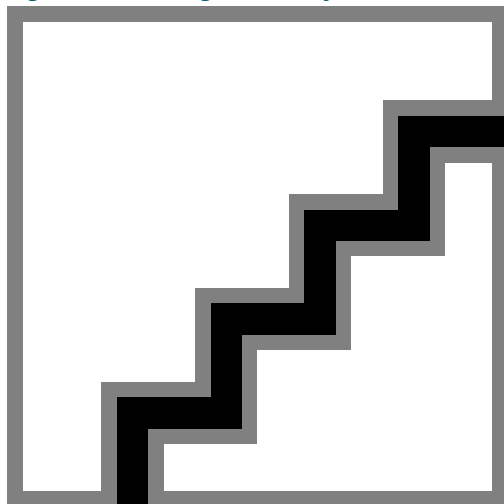

11. Close the light.

Note Refer to the [Open and close an 8-inch Fixture](#) section.

5.3.9 Replace the secondary Cable — Style-6 cord set

Figure 32: Secondary cable replacement



Tools to be used:

- Screwdriver T25 bit (8-inch fixtures) or T30 (12-inch fixtures)
- Flat-head screwdriver
- Small flat head screwdriver

1. Open the light.



Note

Refer to the [Open and close a 12-inch Fixture](#) section.

2. Disconnect the cable:

- a. Disconnect the secondary cable from the converter by placing a small flat-head screwdriver into the opening located at the other side of the secondary wire, and
- b. Release the cable by prying the screwdriver on the cable release opening.

Figure 33: Disconnecting secondary cable

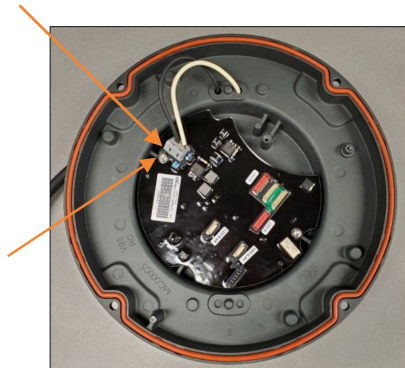

3. Cut the Wire Tie.

4. Remove the nylon hex nut.

Figure 34: Removal of nylon hex nut

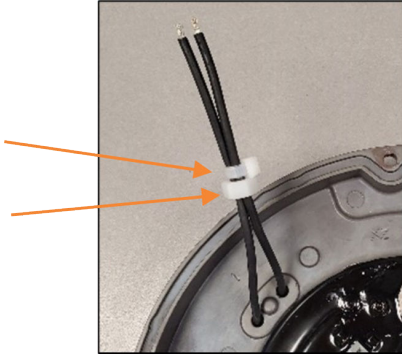

5. Unscrew the Cord-set-retainer Disc Bolt.

Make sure you **dispose the old bolt and Cord-set-retainer disc** and use the new material.

Figure 35: Dispose old bolt and cord-set-retainer disc

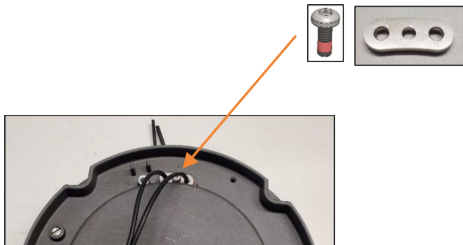

6. Remove the secondary cable.

Make sure you dispose **the old secondary cable** and use the new secondary cable.

7. Remove the old cable gland gaskets.

8. Install the new cable gland gaskets.

Figure 36: New cable gland gasket installation

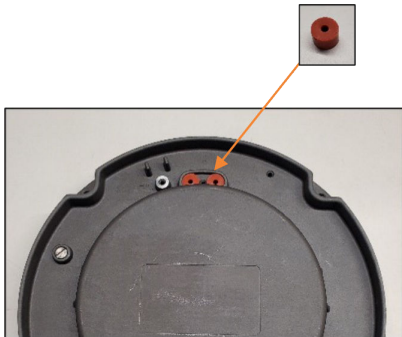

9. Install the new Cord-set-retainer Disc (M4x10) into the Bottom Cover.

Make sure the **Cord-set-retainer Disc** sits loosely in the Bottom Cover.

Figure 37: Loosen cord-set-retainer disc in the bottom cover

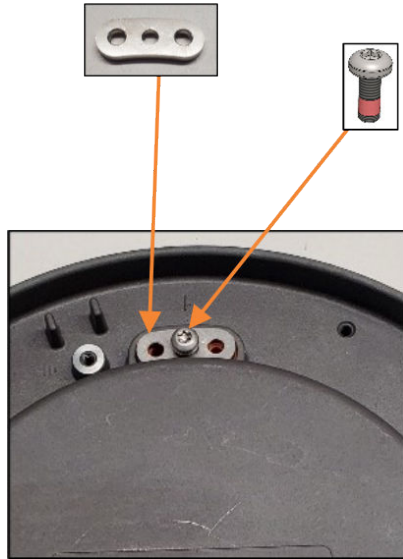

10. Installation:

- a. Pull the new secondary wires through the new Cord-set-retainer Disc Plate.
- b. Pull approximately 4 inches (100 mm) of the secondary cable through the Cord-set-retainer Disc Plate. Make sure the 4-inches of the cable are on the inside of the Bottom Cover.

Figure 38: Installation of secondary cable

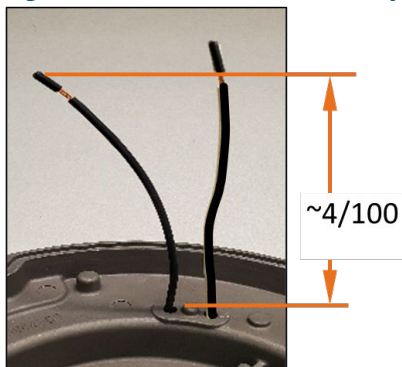

11. Place the new nylon hex nut into cord set.
12. Secure it tightly with a Wire Tie at a position of 2½ inches (64 mm) from the end of the cord set.

Figure 39: Secure nylon hex nut tightly with a wire tie

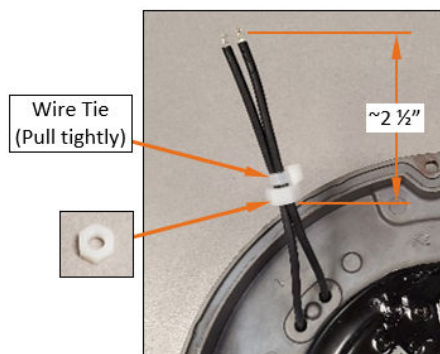

13. Tighten the new Cord-set-retainer Bolt at 26 in-lbs (3 Nm).

Figure 40: Tighten new cold-set-retainer bolt

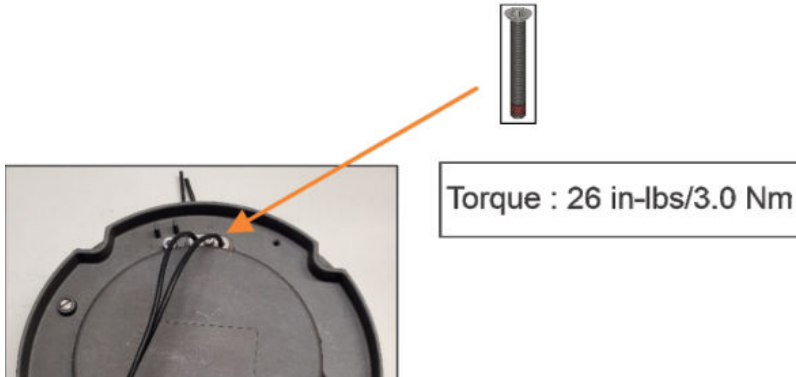

14. Locking:

- Lock the secondary cables leading to the converter by opening the cable holes prying a thin screwdriver on the cable release opening and mounting the wires in place and
- Lock the cables by releasing screwdriver from the opening.

Figure 41: Locking secondary cables

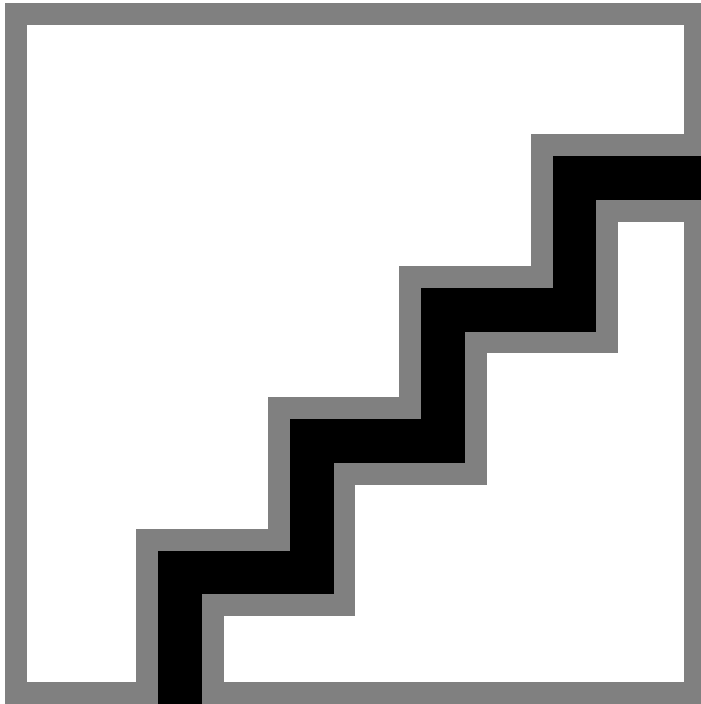

15. Close the light.



Note

Refer to the [Open and close an 8-inch Fixture](#) section.

5.3.10 Replace the secondary Cable — French 3-pin cord set

Tools to be used:

- Screwdriver T25 bit
- Flat-head screwdriver
- Small flat head screwdriver

1. Open the light.



Note

Refer to the [Open and close a 12-inch Fixture](#) section.

2. Disconnect the cable:

- a. Disconnect the secondary cable from the converter by placing a small flat-head screwdriver into the opening located at the other side of the secondary wire, and
- b. Release the cable by prying the screwdriver on the cable release opening.

Figure 42: Disconnecting secondary cable

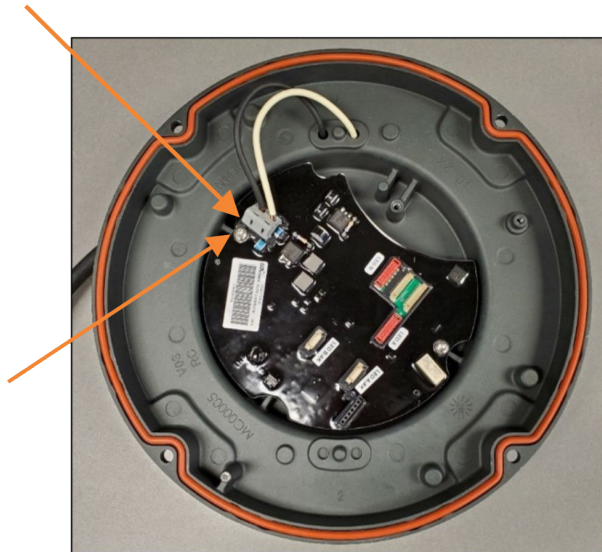

3. Cut the Wire Tie.

4. Remove the nylon hex nut.

Figure 43: Removal of nylon hex nut

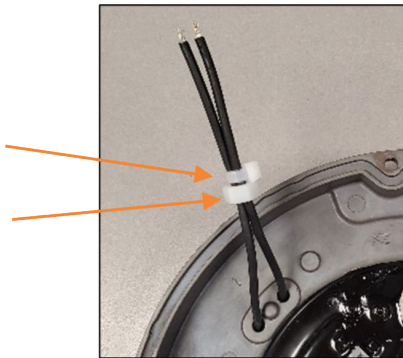

5. Unscrew the Cord-set-retainer Disc Bolt.

Make sure you **dispose the old bolt and Cord-set-retainer disc** and use the new material.

Figure 44: Dispose old bolt and cord-set-retainer-disc

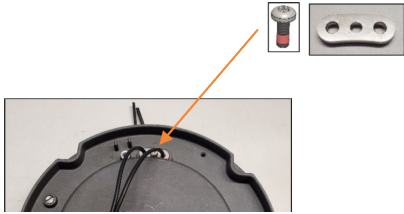

6. Disconnect the ground wire of the cord set from the Bottom Cover.

Make sure you **dispose the old bolt and washer** and use the new material.

Figure 45: Dispose old bolt and washer

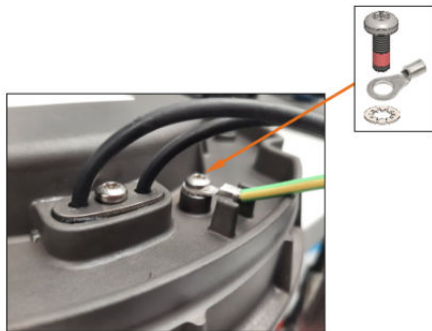

7. Remove the secondary cable.

Make sure you dispose **the old secondary cable** and use the new secondary cable.

8. Remove the old cable gland gaskets.

9. Install the new cable gland gaskets.

Figure 46: Installation of new cable gland gasket

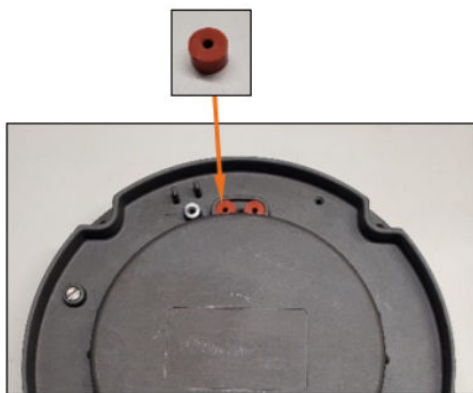

10. Install the new Cord-set-retainer Disc (M4x10) into the Bottom Cover.

Make sure the **Cord-set-retainer Disc** sits loosely in the Bottom Cover.

Figure 47: Loosen cord-set-retainer disc in the bottom cover

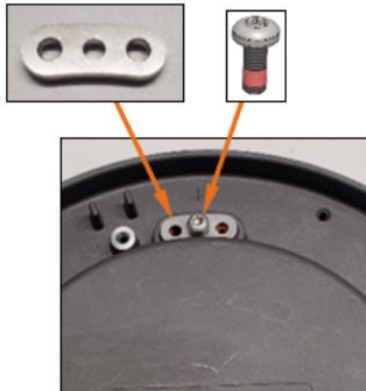

11. Installation:

- a. Pull the new secondary wires through the new Cord-set-retainer Disc Plate.
- b. Pull approximately 4 inches (100 mm) of the secondary cable through the Cord-set-retainer Disc Plate. Make sure the 4-inches of the cable are on the inside of the Bottom Cover.

Figure 48: Installation of new secondary wires

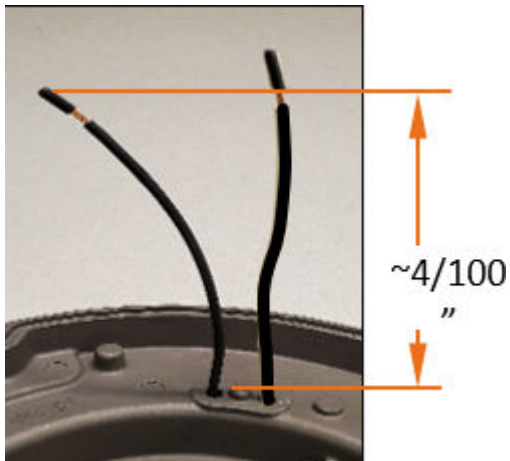

12. Place the new nylon hex nut into cord set.

13. Secure it tightly with a Wire Tie at a position of 2½ inches (64 mm) from the end of the cord set.

Figure 49: Securing nylon hex nut tightly with a wire tie

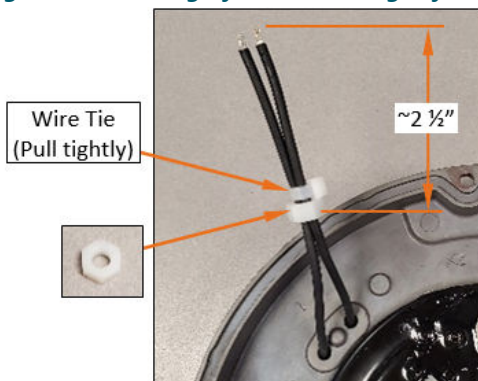

14. Tighten the new Cord-set-retainer Bolt at 26 in-lbs (3 Nm).

Figure 50: Tighten new cold-set-retainer bolt

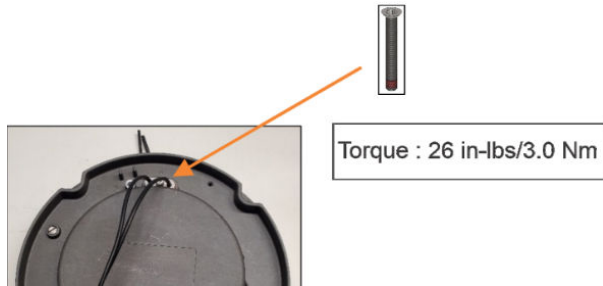

15. Connect the ground wire of the cord set to the Bottom Cover using the bolt and the washer.

16. Tighten the bolt at 26 in-lbs (3.0 Nm).

Figure 51: Tighten bolt

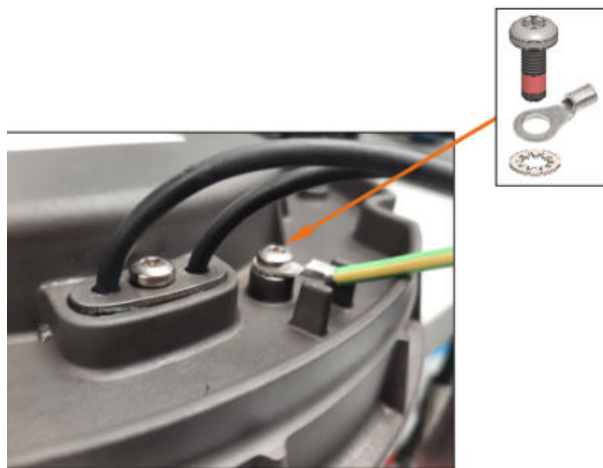

17. Locking:

- Lock the secondary cables leading to the converter by opening the cable holes prying a thin screwdriver on the cable release opening and mounting the wires in place and
- Lock the cables by releasing screwdriver from the opening.

Figure 52: Locking secondary cables



18. Close the light.

i Note Refer to the [Open and close an 8-inch Fixture](#) section.

5.3.11 Reset the Fail-open Converter

Parts

- Fuse resistor spare part kit: 20210209 (20 pcs)

Info

- Converter with 1 connector have 2 fuse resistors
- Converter with 2 connectors have 4 fuse resistors

Reset / replace the fuse resistors

1. Disconnect and disassemble the light fixture.
2. Locate the fuse resistors.



Note

Refer to [Figure 53](#) and [Figure 54](#) figures.

Refer to Figure.

Figure 53: Converter 1

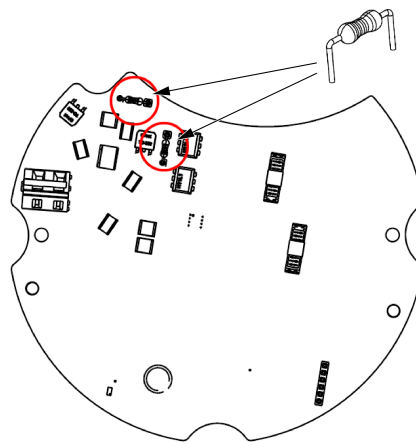
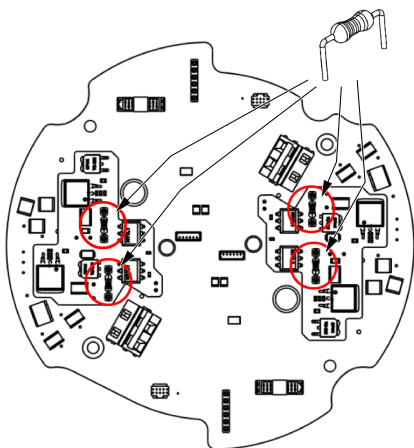

Figure 54: Converter 2



Figures 1 and 2

3. Remove the fuse resistors by pulling away from the converter.
 - a. For converters with 1 connector, always replace both fuse resistors at the same time.
 - b. For converters with 2 connectors, always replace both fuse resistors related to the A/B channel that needs to be reset.

Make sure you replace all 4 fuse resistors, if both A and B channel needs a reset.

4. Dispose the old fuse resistor.
5. Place the legs of the new fuse resistors in the sockets.
6. Assemble the light fixture and perform a functional test.

5.3.12 Check the Light Fixture for Water-tightness

Tools to be used:

- Flat head screwdriver
- For water tight testing, pressure test fitting tool to be used : 44A6104/A

Execute the following procedure to test for leaks:

1. Remove the Pressure-relief Screw.

Refer to the image below.

Figure 55: Removal of pressure-relief screw

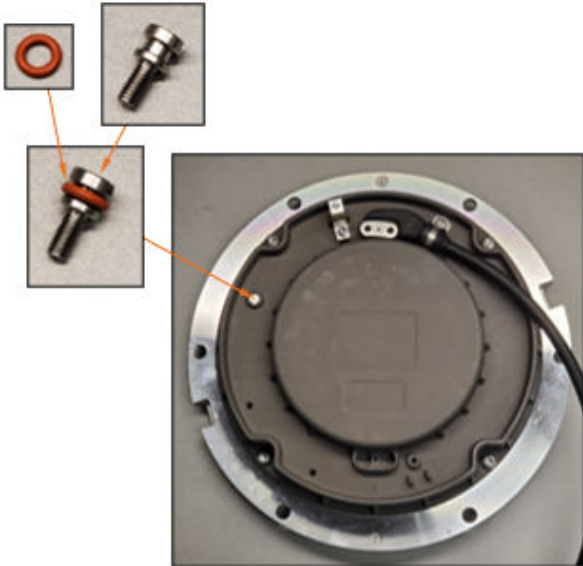

2. Screw the pressure test fitting to the Pressure-relief Port.



NOTICE

The Pressure-relief Port is the opening you created when the pressure relief screw was removed.

3. Screw the fitting hand-tight.

Figure 56: Screw the fitting hand-tight

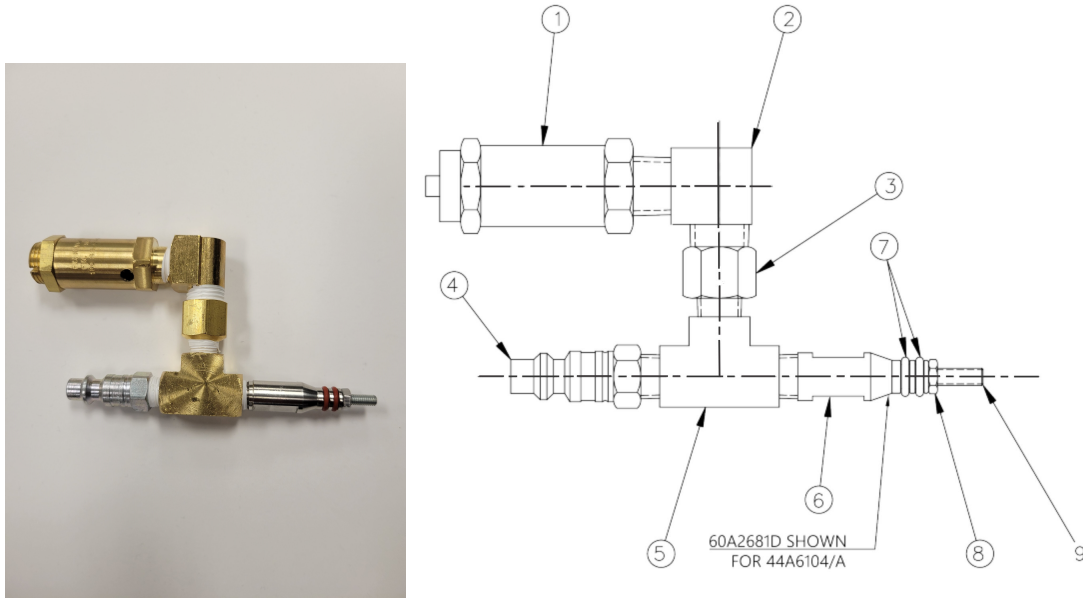

Call-out	Description
1	Pop — safety valve
2	90 deg., elbow, female X male, brass, 1/4"
3	Adapter, female — male, 1/4 x 1/8, brass
4	Sleeve — lock hose plug, 1/4" coupler
5	Tee, brass, 1/8
6	Pressure test fitting, body
7	O-ring, silicone, size 008, 1/16 W X 3/16
8	M4 Hex Jam nut, 18-8 SS
9	Pressure test fitting stud

4.

5. Attach the shop airline to the Lock Hose Plug Sleeve (2).

6. Pressurize to 20 psi (130 kPa).

7. Submerge the pressure test fitting in a water tank.

8. Wait 3 minutes and check if air leaks out of the light.

If air leaks out of the light fixture (between the Bottom Cover and the top plate or between the prism and top plate or water-tightness valve and top plate), the light fixture is not watertight and must be repaired. Release the air from the light. Disassemble the light fixture and re-check the mating surfaces and gaskets. Assemble the light fixture and perform the water-tightness test again.

9. Depressurize and reinstall the pressure release screw (1) at 26 in-lbs (3 Nm), if the fixture is watertight.



DANGER

Never exceed a pressure of 22 psi (150 kPa) inside the light fixture. A higher pressure may cause injuries and damage the light.

6.0 Ordering Codes

6.1 Ordering Code L-850C(L) Runway Edge 45m ICAO & FAA

Ordering Code	RS																			
Application RE = L-850C(L) Runway Edge ≤ 45 m width runway																				
Standards 1 = FAA/ICAO ¹																				
Market Specific 0 = None 1 = Buy American Preference (BAP) ^{2,3} 4 = German MIL 7-step FO ⁸																				
Dimensions 2 = 12 inch (305 mm) diameter, 11.25 inch BC (285 mm)																				
Prism S = Standard prism R = Reinforced prism ⁸																				
Beam Orientation 1 = Unidirectional 2 = Bidirectional																				
Toe-in C = Curved (bidirectional application) L = Left (unidirectional application) R = Right (unidirectional application)																				
Color – Side 1 (Left) W= White Y = Yellow R = Red F = F-Green																				
Color – Side 2 (Right) W= White Y = Yellow R = Red F = F-Green N= None																				
Power and Monitoring S = 2.8 A - 6.6 A, non-monitored — power only ⁴ M = 2.8 A - 6.6 A, Fail-open monitoring ^{4,8} R = 2.8 A - 6.6 A EQ integrated LINC 360																				
Cable and Connector 1 = 1 x Style 6 2-pole plug, 2 individual wires ^{5,8} 2 = 1 x Style 1 2-pole plug ⁵ 3 = 2 x Style 6 2-pole plug, 2 individual wires ^{5,6,8} 4 = 2 x Style 1 2-pole plug ^{5,6,8} 5 = 1 x Flat 3-pole plug, 3 individual wires ⁸ 6 = 2 x Flat 3-pole plug, 3 individual wires ^{5,8}																				
Options 0 = None 1 = Arctic Kit ⁷																				
Version 1 = Version 1																				

Ordering Code Notes

Fixture supports: Compatible with both shallow and deep 12-inch bases.

EQ light fixtures are only available as a one connector option.

¹Includes standards NATO, EASA, STAC, CAP 168, TP 312 and MOS 139.

² Required when FAA AIP funded.

³ If a 2-cord set fixture is required meeting BAP, digit 13, "Power and Monitoring", must be M.

⁴ 2 x Style 1 or 6 options are available under "Cable and Connector".

⁵ All Style 1 corded fixtures will include a ground lug. All Style 6 corded fixtures will be provided without a ground lug.

⁶ Only available in Power and Monitoring options S and M.

⁷ RE white/white and white/yellow applications meet the heat rise requirements in Engineering Brief 67D, section 2.13.1, "Arctic Kit Testing Requirements" WITHOUT an arctic kit. We do not offer an Arctic Kit with this configuration as the additional heat would be detrimental to the life of the LEDs.

⁸ Not ETL submitted or not applicable to FAA market.

6.2 Ordering Code L-850A(L) Runway Centerline , L-850B(L) Touchdown Zone (ICAO & FAA)

Ordering Code	RS	□	□	□	□	□	□	□	□	□	□
Application RC = Runway Centerline, L-850A(L) RZ = Touchdown Zone, L-850B(L)											
Standards 1 = FAA/ICAO ¹											
Market Specific 0 = None 1 = Buy American Preference (BAP) ^{2,3} 4 = German MIL 7-step FO ⁸											
Dimensions 1 = 8 inch (203 mm) diameter 2 = 12 inch (305 mm) diameter, 11.25 inch BC (285 mm) 3 = 8 inch (203 mm) diameter, 4-bolt											
Prism S = Standard prism R = Reinforced prism ⁸											
Beam Orientation 1 = Unidirectional 2 = Bidirectional											
Toe-in N = None ⁴ L = Left (only for RZ) ⁴ R = Right (only for RZ) ⁴											
Color – Side 1 W = White R = Red											
Color – Side 2 W = White R = Red N = None (Unidirectional app only)											
Power and Monitoring S = 2.8 A - 6.6 A, non-monitored — power only ⁵ M = 2.8 A - 6.6 A, Fail-open monitoring ^{5,10} R = 2.8 A - 6.6 A EQ integrated LINC 360											
Cable and Connector 1 = 1 x Style 6 2-pole plug, 2 individual wires ^{6,10} 2 = 1 x Style 1 2-pole plug, jacketed SO 2 core cable ⁶ 3 = 2 x Style 6 2-pole plug, 2 individual wires ^{6,7,10} 4 = 2 x Style 1 2-pole plug, jacketed SO 2 core cable ^{6,7,10} 5 = 1 x Flat 3-pole plug, 3 individual wires ^{6,10} 6 = 2 x Flat 3-pole plug, 3 individual wires ^{8,10}											
Options 0 = None ⁹ 1 = Arctic Kit ⁹											
Version 1 = Version 1											

Ordering Code Notes

EQ light fixtures are only available as a one connector option.

¹ Includes standards NATO, EASA, STAC, CAP 168, TP 312 and MOS 139.

² Required for FAA when using AIP funds.

³ If a 2-cord set fixture is required meeting BAP, Digit 13, "Power and Monitoring", must be M.

⁴ L and R designations are always in relationship to Side 1 only.

⁵ 2-cord set option available

⁶ All Style 1 corded fixtures will include a ground lug. All Style 6 corded fixtures will be provided without a ground lug.

⁷ Only available in Digit 13 options S and M and bi-directional configuration

⁸ Not valid option for uni-directional

⁹ RC white/white application meets the heat rise requirements in Engineering Brief 67D, section 2.13.1, "Arctic Kit Testing Requirements" WITHOUT an arctic kit. We do not offer an arctic kit with this configuration as the additional heat would be detrimental to the life of the LEDs.

¹⁰ Not ETL-submitted or not applicable to FAA market

6.3 Ordering Code Threshold, End & Threshold/End L-850D(L) (FAA)

Ordering Code	RS	□	□	□	□	□	□	□	□	□	□	□
Application RT = L-850D(L) Runway Threshold, Threshold End RN = L-850D(L) Runway End												
Standards 2 = FAA												
Market Specific 0 = None 1 = Buy American Preference (BAP) ^{1,2}												
Dimensions 2 = 12 inch (305 mm) diameter, 11.25 inch BC (285 mm)												
Prism S = Standard prism R = Reinforced prism												
Beam Orientation 1 = Unidirectional 2 = Bidirectional												
Toe-in N = None (RN must be N) ³ L = Left (RT Green only, always toed) ³ R = Right (RT Green only, always toed) ³												
Color – Side 1 F = F-Green (Arctic kit required) R = Red (Arctic kit not required)												
Color – Side 2 R = Red (Arctic kit not required) N = None												
Power and Monitoring S = 2.8 A - 6.6 A, non-monitored — power only ⁴ M = 2.8 A - 6.6 A, Fail-open monitoring ⁴ R = 2.8 A - 6.6 A, EQ integrated LINC 360												
Cable and Connector 1 = 1 x Style 6 2-pole plug, 2 individual wires ^{4,5,8} 2 = 1 x Style 1 2-pole plug, jacketed SO 2 core cable ^{4,5} 3 = 2 x Style 6 2-pole plug, 2 individual wires ^{4,5,6,8} 4 = 2 x Style 1 2-pole plug, jacketed SO 2 core cable ^{4,5,6,8}												
Options 0 = None ⁷ 1 = Arctic Kit ⁷												
Version 1 = Version 1												

Ordering Code Notes

Fixture supports: Compatible with both shallow and deep 12-inch bases.

EQ light fixtures are only available as a one connector option.

¹ Required when FAA AIP funded

² If a 2-cord set fixture is required meeting BAP, digit 13, "Power and Monitoring", must be M.

³ L and R designations are always in relationship to Side 1 only.

⁴ 2-cord set option available

⁵ All Style 1 corded fixtures will include a ground lug. All Style 6 corded fixtures will be provided without a ground lug.

⁶ Only available in Digit 13 options S and M and bi-directional configuration

⁷ RN red application meets the heat rise requirements in Engineering Brief 67D, section 2.13.1, "Arctic Kit Testing Requirements" WITHOUT an arctic kit. We do not offer an arctic kit with this configuration as the additional heat would be detrimental to the life of the LEDs.

⁸ Not ETL submitted or not applicable to FAA market

6.4 Ordering Code ICAO & FAA L-850T(L) Takeoff/Hold (THL) & (RIL)Runway Intersection

Ordering Code	RS												
Application RS = Runway Status; Takeoff/ Hold (THL); L-850T(L) (RIL); Runway Intersection ¹ TS = Runway Status; Runway Entry (REL) ¹													
Standards 2 = FAA													
Market Specific 0 = None 1 = Buy American Preference (BAP)													
Dimensions 1 = 8 inch (203 mm) diameter ² 2 = 12 inch (305 mm) diameter 11.25 inch BC (285 mm) 3 = 8 inch (203 mm) diameter 4-bolt ²													
Prism S = Standard prism R = Reinforced prism ²													
Beam Orientation 1 = Unidirectional													
Toe-in N= None													
Color – Side 1 R = Red													
Color – Side 2 N= Not applicable													
Power and Monitoring R = 2.8 A - 6.6 A, EQ integrated LINC 360													
Cable and connector ¹ 1 = 1 x Style 6 2-pole plug, 2 individual Wires 2 = 1 x Style 1 2-pole plug, jacketed SO 2-core cable													
Options 0 = None 1 = Arctic Kit													
Version Control 1 = Version 1													

Ordering Code Notes

¹ All Style 1 corded fixtures will include a ground lug. All Style 6 and 3-pole corded fixtures will be provided with grounding screw(s).

² Not ETL submitted

6.5 Ordering Code Stopway 45m (ICAO)

Ordering Code

RS

Application

SW= Stopway 45 m

Standards

3 = ICAO

Market Specific

0 = None

Dimensions

2 = 12 inch (305 mm) diameter, 11.25 inch BC (285 mm)

Prism

S = Standard prism

R = Reinforced prism

Beam Orientation

1 = Unidirectional

Toe-in

L = Left¹

R = Right¹

Color (Side 1 – Left)

R = Red

Color (Side 2 – Right)

N= None

Power and Monitoring

S = 2.8 A - 6.6 A non-monitored - power only

M= 2.8 A - 6.6 A Fail-Open monitoring

R = 2.8 A - 6.6 A, ILCMS integrated OFDM EQ

Cable and Connector

1 = 1 x Style 6 2-pole plug, 2 individual wires²

2 = 1 x Style 1 2-pole plug, jacketed SO 2-core cable^{2,3}

5 = 1 x flat 3-pole plug, 3 individual wires²

Options

0 = None

1 = Arctic Kit

Version Control

1 = Version 1

Ordering Code Notes

Fixture supports: Compatible with both shallow and deep 12-inch bases.

EQ light fixtures are only available as a one connector option.

¹L and R designations are always in relationship to Side 1 only.

²2-cord set option available

³All Style 1 corded fixtures will include a ground lug. All Style 6 or 3-pole corded fixtures will be provided without a ground lug.

⁴1Style 1 SO cord-set are not compatible with shallow bases

7.0 Spare Parts

Spare parts are available for inset light fixtures with and without the control and monitoring functionality. For more information, see www.adbsafegate.com and the spare part lists, or contact ADB SAFEGATE for assistance.

7.1 Versions and Exploded View

Versions, 12-inch Insets

Partial Exploded View — Spare part Assemblies

Figure 57: 8-inch fixtures (left) & 12-inch fixtures(right)

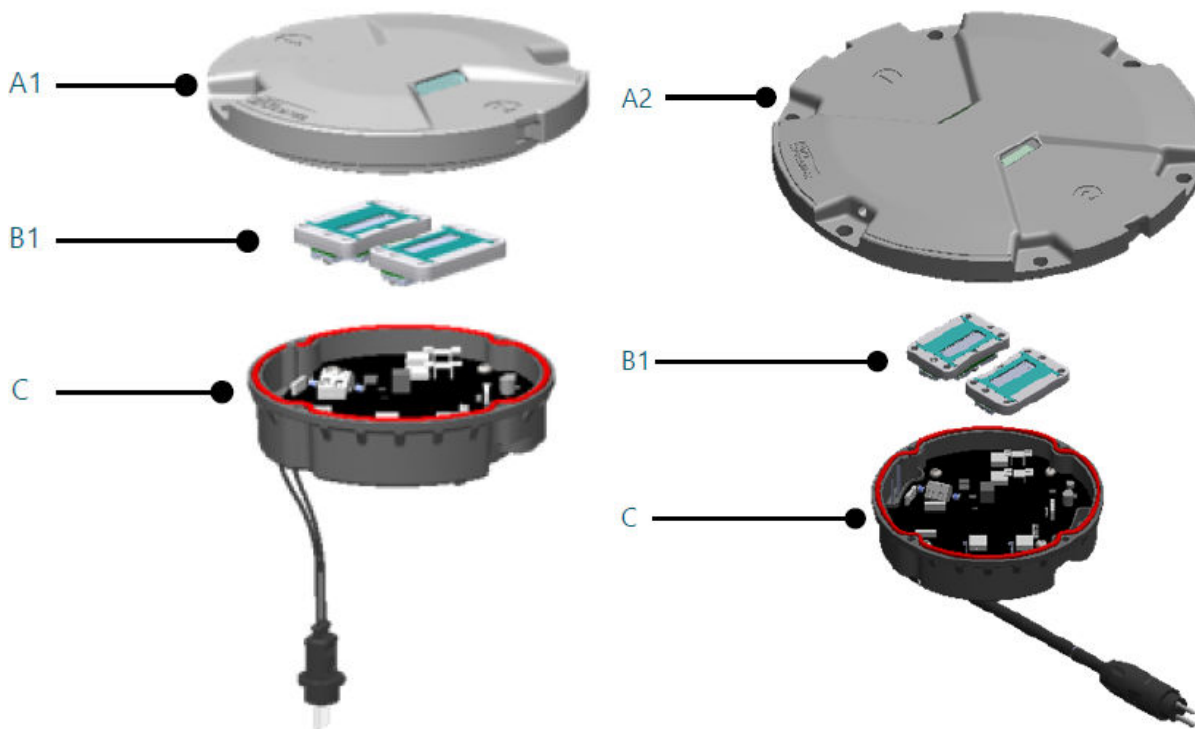

Table 1: Exploded View Legend — Spare part assemblies, 8-inch and 12-inch

Call-out	Description	Assembly number prefix
A1	Top Cover Assembly, 8-inch	SP.AS00019-XXX
A2	Top Cover Assembly, 12-inch	SP.AS00018-XXX
B1	Light Engine Assembly, 8-inch and 12-inch	SP.AS00023-XXX SP.AS00020-XXX
C	Bottom Pan Assembly, 8-inch and 12-inch	SP.AS00024-XXX SP.AS00021-XXX

7.2 Spare Parts - Runway Edge 45m ICAO & FAA



Note

- Each Top Cover Assembly includes a Bottom Cover Gasket and a Bottom Cover Screws.
- BAP stands for "Buy American Preference".

A2 - Top cover assemblies, 12-inch with heater	Quantity per		spare part code
	fitting	spare part	
unidirectional, standard prism, non-monitored (S-BAP) and EQ (R)	1	1	SPAS00018-UAG
unidirectional, reinforced prism, non-monitored (S-BAP) and EQ (R)	1	1	SPAS00018-UAS
unidirectional, standard prism, non-monitored (S-non-BAP) and monitored (M)	1	1	SPAS00018-UBG
unidirectional, reinforced prism, non-monitored (S-non-BAP) and monitored (M)	1	1	SPAS00018-UBS
bidirectional, standard prism, non-monitored (S-BAP) and EQ (R)	1	1	SPAS00018-BAG
bidirectional, reinforced prism, non-monitored (S-BAP) and EQ (R)	1	1	SPAS00018-BAS
bidirectional, standard prism, non-monitored (S-non-BAP) and monitored (M)	1	1	SPAS00018-BBG
bidirectional, reinforced prism, non-monitored (S-non-BAP) and monitored (M)	1	1	SPAS00018-BBS

A2 - Top Cover assemblies, 12", no heater	Quantity per		spare part code
	fitting	spare part	
unidirectional, standard prism	1	1	SPAS00018-UNG
unidirectional, reinforced prism	1	1	SPAS00018-UNS
bidirectional, standard prism	1	1	SPAS00018-BNG
bidirectional, reinforced prism	1	1	SPAS00018-BNS

B1- Light engine assembly, 12"	Quantity per		spare part code
	fitting	spare part	
FAA L-850C(L), F-green, left toe	1	1	SPAS00023-LF2-RE
FAA L-850C(L), F-green, right toe	1	1	SPAS00023-RF2-RE
ICAO and FAA L-850C(L), red, left toe	1	1	SPAS00023-LR2
ICAO and FAA L-850C(L), red, right toe	1	1	SPAS00023-RR2
ICAO and FAA L-850C(L), white, left toe	1	1	SPAS00023-LW3
ICAO and FAA L-850C(L), white, right toe	1	1	SPAS00023-RW3
ICAO and FAA L-850C(L), yellow, left toe	1	1	SPAS00023-LY3
ICAO and FAA L-850C(L), yellow, right toe	1	1	SPAS00023-RY3

C - Bottom pan assembly, 12"	Quantity per		spare part code
	fitting	spare part	
non-monitored converter, style 6 cord set	1	1	SP.AS00024-L13
non-monitored converter, 3-pole cord set	1	1	SP.AS00024-L1F
non-monitored converter, style 1 SJO jacketed cord set	1	1	SP.AS00024-L1J
non-monitored converter, 2-con style 6 cord sets	1	1	SP.AS00024-L23
non-monitored converter, 2-con 3-pole cord sets	1	1	SP.AS00024-L2F
non-monitored converter, 2-con style 1 SJO jacketed cord sets	1	1	SP.AS00024-L2J
monitored converter, style 6 cord set	1	1	SP.AS00024-M13
monitored converter, 3-pole cord set	1	1	SP.AS00024-M1F
monitored converter, style 1 SJO jacketed cord set	1	1	SP.AS00024-M1J
monitored converter, 2-con style 6 cord sets	1	1	SP.AS00024-M23
monitored converter, 2-con 3-pole cord sets	1	1	SP.AS00024-M2F
monitored converter, 2-con style 1 SJO jacketed cord sets	1	1	SP.AS00024-M2J
EQ converter, style 6 cord set	1	1	SP.AS00024-R13
EQ converter, 3-pole cord set	1	1	SP.AS00024-R1F
EQ converter, style 1 SJO jacketed cord set	1	1	SP.AS00024-R1J
Buy American Preference non-monitored converter, style 6 cord set	1	1	SP.AS00024-S13
Buy American Preference non-monitored converter, style 1 SJO jacketed cord set	1	1	SP.AS00024-S1J

Cordsets	Quantity per		spare part code
	fitting	spare part	
Cord set, L-823 style 1, 8" bottom pan, package of 5	1 or 2	5	SP.73A0193/1
Cord set, L-823 style 1, 12" bottom pan, package of 5	1 or 2	5	SP.73A0194/1
Cord set, L-823 style 6, 8" & 12" bottom pan, package of 5	1 or 2	5	SP.SGE96253351
Cord set, 3-pole, 8" & 12" bottom pan, package of 5	1 or 2	5	SP.SGEFR500160
Cable retaining clamp, for use with style 1 cord set, package of 5	1 or 2	5	SP.MB00003-013-01
Ground lug kit, package of 5	1	5	SP.72A0401

Prism spares	Quantity per		spare part code
	fitting	spare part	
Prism kit, runway standard, package of 2	1 or 2	2	SP.MG00001-G00-03
Prism kit, runway reinforced, package of 2	1 or 2	2	SP.MG00001-S00-03
Prism gasket, Runway, package of 10	1 or 2	10	SP.MS00004-000-02

screws & gaskets	Quantity per		spare part code
	fitting	spare part	
Pressure release screw with o-ring, package of 5	1	5	SP.MF00090-000-01
Gasket, 12" Bottom pan, package of 10	1	10	SP.MS00006-000-01
Screws, light engine assembly mounting, package of 100	-	100	SP.MFPM4PT-710-01
Screws, 12" Bottom pan, package of 100	-	100	SP.MFPM6PT-720-01

Heater kits	Quantity per		spare part code
	fitting	spare part	
Heater kit with harness - non-monitored (S-BAP) & EQ, package of 2	1 or 2	2	SPEP00038-R00-01
Heater kit with harness - non-monitored (S-non-BAP) & monitored, package of 2	1 or 2	2	SPEP00038-R01-01

Wire harness	Quantity per		spare part code
	fitting	spare part	
Wire harness, power supply to light engine, package of 10	1 or 2	10	SPEW00079-000-01

Fuse	Quantity per		spare part code
	fitting	spare part	
Fuse Resistors (only for fixtures with monitoring (M))	1 or 2	20	6132.00.250

 **Note**

All screws for fastening are included.

Component availability or design may be subject to change due to unforeseen circumstances. This document is subject to change or new information from ADB SAFEGATE, as and when available or if required, with reservation for error or price changes.

For more information or assistance with ordering spare parts, contact ADB SAFEGATE, see www.adbsafegate.com.

7.3 Spare Parts - Centerline ICAO & FAA



Note

- Each Top Cover Assembly includes a Bottom Cover Gasket and a Bottom Cover Screws.
- BAP stands for "Buy American Preference".

A1 - Top Cover assemblies (2-bolt), 8", no heater	Quantity per		spare part code
	fitting	spare part	
unidirectional, standard prism	1	1	SPAS00019-3NG
unidirectional, reinforced prism	1	1	SPAS00019-3NS
bidirectional, standard prism	1	1	SPAS00019-4NG
bidirectional, reinforced prism	1	1	SPAS00019-4NS

A1 - Top Cover assemblies (2-bolt), 8", with heater	Quantity per		spare part code
	fitting	spare part	
unidirectional, standard prism, non-monitored (S-BAP) and EQ (R)	1	1	SPAS00019-3AG
unidirectional, reinforced prism, non-monitored (S-BAP) and EQ (R)	1	1	SPAS00019-3AS
unidirectional, standard prism, non-monitored (S-non-BAP) and monitored (M)	1	1	SPAS00019-3BG
unidirectional, reinforced prism, non-monitored (S-non-BAP) and monitored (M)	1	1	SPAS00019-3BS
bidirectional, standard prism, non-monitored (S-BAP) and EQ (R)	1	1	SPAS00019-4AG
bidirectional, reinforced prism, non-monitored (S-BAP) and EQ (R)	1	1	SPAS00019-4AS
bidirectional, standard prism, non-monitored (S-non-BAP) and monitored (M)	1	1	SPAS00019-4BG
bidirectional, reinforced prism, non-monitored (S-non-BAP) and monitored (M)	1	1	SPAS00019-4BS

A1 - Top Cover assemblies (4-bolt), 8", no heater	Quantity per		spare part code
	fitting	spare part	
unidirectional, standard prism	1	1	SPAS00019-5NG
unidirectional, reinforced prism	1	1	SPAS00019-5NS
bidirectional, standard prism	1	1	SPAS00019-6NG
bidirectional, reinforced prism	1	1	SPAS00019-6NS

A1 - Top Cover assemblies (4-bolt), 8", with heater	Quantity per		spare part code
	fitting	spare part	
unidirectional, standard prism, non-monitored (S-BAP) and EQ (R)	1	1	SPAS00019-5AG
unidirectional, reinforced prism, non-monitored (S-BAP) and EQ (R)	1	1	SPAS00019-5AS
unidirectional, standard prism, non-monitored (S-non-BAP) and monitored (M)	1	1	SPAS00019-5BG
unidirectional, reinforced prism, non-monitored (S-non-BAP) and monitored (M)	1	1	SPAS00019-5BS

A1 - Top Cover assemblies (4-bolt), 8", with heater	Quantity per		spare part code
	fitting	spare part	
bidirectional, standard prism, non-monitored (S-BAP) and EQ (R)	1	1	SP.AS00019-6AG
bidirectional, reinforced prism, non-monitored (S-BAP) and EQ (R)	1	1	SP.AS00019-6AS
bidirectional, standard prism, non-monitored (S-non-BAP) and monitored (M)	1	1	SP.AS00019-6BG
bidirectional, reinforced prism, non-monitored (S-non-BAP) and monitored (M)	1	1	SP.AS00019-6BS

A2 - Top Cover assemblies, 12", no heater	Quantity per		spare part code
	fitting	spare part	
unidirectional, standard prism	1	1	SP.AS00018-UNG
unidirectional, reinforced prism	1	1	SP.AS00018-UNS
bidirectional, standard prism	1	1	SP.AS00018-BNG
bidirectional, reinforced prism	1	1	SP.AS00018-BNS

A2 - Top Cover assemblies, 12", with heater	Quantity per		spare part code
	fitting	spare part	
unidirectional, standard prism, non-monitored (S-BAP) and EQ (R)	1	1	SP.AS00018-UAG
unidirectional, reinforced prism, non-monitored (S-BAP) and EQ (R)	1	1	SP.AS00018-UAS
unidirectional, standard prism, non-monitored (S-non-BAP) and monitored (M)	1	1	SP.AS00018-UBG
unidirectional, reinforced prism, non-monitored (S-non-BAP) and monitored (M)	1	1	SP.AS00018-UBS
bidirectional, standard prism, non-monitored (S-BAP) and EQ (R)	1	1	SP.AS00018-BAG

A2 - Top Cover assemblies, 12", with heater	Quantity per		spare part code
	fitting	spare part	
bidirectional, reinforced prism, non-monitored (S-BAP) and EQ (R)	1	1	SPAS00018-BAS
bidirectional, standard prism, non-monitored (S-non-BAP) and monitored (M)	1	1	SPAS00018-BBG
bidirectional, reinforced prism, non-monitored (S-non-BAP) and monitored (M)	1	1	SPAS00018-BBS

B1 - Light engine assembly, 8"	Quantity per		spare part code
	fitting	spare part	
ICAO and FAA L-850A(L), red, straight	1 or 2	1	SPAS00020-SR1
ICAO and FAA L-850A(L)/L-850B(L), white, straight	1 or 2	1	SPAS00020-SW2

B1 - Light engine assembly, 12"	Quantity per		spare part code
	fitting	spare part	
ICAO and FAA L-850A(L), red, straight	1 or 2	1	SPAS00023-SR1
ICAO and FAA L-850A(L), white, straight	1 or 2	1	SPAS00023-SW2

C - Bottom pan assembly, 12"	Quantity per		spare part code
	fitting	spare part	
non-monitored converter, style 6 cord set	1	1	SPAS00024-L13
non-monitored converter, 3-pole cord set	1	1	SPAS00024-L1F
non-monitored converter, style 1 SJO jacketed cord set	1	1	SPAS00024-L1J
non-monitored converter, 2-con style 6 cord sets	1	1	SPAS00024-L23
non-monitored converter, 2-con 3-pole cord sets	1	1	SPAS00024-L2F
non-monitored converter, 2-con style 1 SJO jacketed cord sets	1	1	SPAS00024-L2J
monitored converter, style 6 cord set	1	1	SPAS00024-M13
monitored converter, 3-pole cord set	1	1	SPAS00024-M1F
monitored converter, style 1 SJO jacketed cord set	1	1	SPAS00024-M1J
monitored converter, 2-con style 6 cord sets	1	1	SPAS00024-M23
monitored converter, 2-con 3-pole cord sets	1	1	SPAS00024-M2F
monitored converter, 2-con style 1 SJO jacketed cord sets	1	1	SPAS00024-M2J
EQ converter, style 6 cord set	1	1	SPAS00024-R13
EQ converter, 3-pole cord set	1	1	SPAS00024-R1F

C - Bottom pan assembly, 12"	Quantity per		spare part code
	fitting	spare part	
EQ converter, style 1 SJO jacketed cord set	1	1	SPAS00024-R1J
Buy American Preference non-monitored converter, style 6 cord set	1	1	SPAS00024-S13
Buy American Preference non-monitored converter, style 1 SJO jacketed cord set	1	1	SPAS00024-S1J

C - Bottom pan assembly, 8"	Quantity per		spare part code
	fitting	spare part	
non-monitored converter, style 6 cord set	1	1	SPAS00021-L13
non-monitored converter, 3-pole cord set	1	1	SPAS00021-L1F
non-monitored converter, style 1 SJO jacketed cord set	1	1	SPAS00021-L1J
non-monitored converter, 2-con style 6 cord sets	1	1	SPAS00021-L23
non-monitored converter, 2-con 3-pole cord sets	1	1	SPAS00021-L2F
non-monitored converter, 2-con style 1 SJO jacketed cord sets	1	1	SPAS00021-L2J
monitored converter, style 6 cord set	1	1	SPAS00021-M13
monitored converter, 3-pole cord set	1	1	SPAS00021-M1F
monitored converter, style 1 SJO jacketed cord set	1	1	SPAS00021-M1J
monitored converter, 2-con style 6 cord sets	1	1	SPAS00021-M23
monitored converter, 2-con 3-pole cord sets	1	1	SPAS00021-M2F
monitored converter, 2-con style 1 SJO jacketed cord sets	1	1	SPAS00021-M2J
EQ converter, style 6 cord set	1	1	SPAS00021-R13
EQ converter, 3-pole cord set	1	1	SPAS00021-R1F
EQ converter, style 1 SJO jacketed cord set	1	1	SPAS00021-R1J
Buy American Preference non-monitored converter, style 6 cord set	1	1	SPAS00021-S13
Buy American Preference non-monitored converter, style 1 SJO jacketed cord set	1	1	SPAS00021-S1J

Cordsets	Quantity per		spare part code
	fitting	spare part	
Cord set, L-823 style 1, 8" bottom pan	1 or 2	5	SP.73A0193/1
Cord set, L-823 style 1, 12" bottom pan	1 or 2	5	SP.73A0194/1
Cord set, L-823 style 6, 8" & 12" bottom pan	1 or 2	5	SP.SGE96253351
Cord set, 3-pole, 8" & 12" bottom pan	1 or 2	5	SP.SGEFR500160
Cable retaining clamp, for use with style 1 cord set	1 or 2	5	SP.MB00003-013-01
Ground lug kit	1	5	SP.72A0401

Prism spares	Quantity per		spare part code
	fitting	spare part	
Prism kit, runway standard	1 or 2	2	SP.MG00001-G00-03
Prism kit, runway reinforced	1 or 2	2	SP.MG00001-S00-03
Prism gasket, Runway	1 or 2	10	SP.MS00004-000-02

screws & gaskets	Quantity per		spare part code
	fitting	spare part	
Pressure release screw with o-ring	1	5	SPMF00090-000-01
Gasket, 8" Bottom pan	1	10	SPMS00005-000-01
Screws, 8" Bottom pan	-	100	SPMFPM5PT-714-01
Gasket, 12" Bottom pan	1	10	SPMS00006-000-01
Screws, light engine assembly mounting	-	100	SPMFPM4PT-710-01
Screws, 12" Bottom pan	-	100	SPMFPM6PT-720-01

Heater kits	Quantity per		spare part code
	fitting	spare part	
Heater kit with harness - non-monitored (S-BAP) & EQ	1 or 2	2	SP.EP00038-R00-01
Heater kit with harness - non-monitored (S-non-BAP) & monitored	1 or 2	2	SP.EP00038-R01-01

Wire harness	Quantity per		spare part code
	fitting	spare part	
Wire harness, power supply to light engine	1 or 2	10	SPEW00079-000-01

Fuse	Quantity per		spare part code
	fitting	spare part	
Fuse Resistors (only for fixtures with monitoring (M))	1 or 2	20	6132.00.250



Note

All screws for fastening are included.

Component availability or design may be subject to change due to unforeseen circumstances. This document is subject to change or new information from ADB SAFEGATE, as and when available or if required, with reservation for error or price changes.

For more information or assistance with ordering spare parts, contact ADB SAFEGATE, see www.adbsafegate.com.

7.4 Spare Parts - Touchdown Zone ICAO & FAA



Note

- Each Top Cover Assembly includes a Bottom Cover Gasket and a Bottom Cover Screws.
- BAP stands for "Buy American Preference".

A2 - Top Cover assemblies, 12", no heater	Quantity per		spare part code
	fitting	spare part	
unidirectional, standard prism	1	1	SP.AS00018-UNG
unidirectional, reinforced prism	1	1	SP.AS00018-UNS

A2 - Top Cover assemblies, 12", with heater	Quantity per		spare part code
	fitting	spare part	
unidirectional, standard prism, non-monitored (S-BAP) and EQ (R)	1	1	SP.AS00018-UAG
unidirectional, reinforced prism, non-monitored (S-BAP) and EQ (R)	1	1	SP.AS00018-UAS
unidirectional, standard prism, non-monitored (S-non-BAP) and monitored (M)	1	1	SP.AS00018-UBG
unidirectional, reinforced prism, non-monitored (S-non-BAP) and monitored (M)	1	1	SP.AS00018-UBS

A1 - Top Cover assemblies (2-bolt), 8", no heater	Quantity per		spare part code
	fitting	spare part	
unidirectional, standard prism	1	1	SP.AS00019-3NG
unidirectional, reinforced prism	1	1	SP.AS00019-3NS

A1 - Top Cover assemblies (2-bolt), 8", with heater	Quantity per		spare part code
	fitting	spare part	
unidirectional, standard prism, non-monitored (S-BAP) and EQ (R)	1	1	SP.AS00019-3AG
unidirectional, reinforced prism, non-monitored (S-BAP) and EQ (R)	1	1	SP.AS00019-3AS
unidirectional, standard prism, non-monitored (S-non-BAP) and monitored (M)	1	1	SP.AS00019-3BG
unidirectional, reinforced prism, non-monitored (S-non-BAP) and monitored (M)	1	1	SP.AS00019-3BS

A1 - Top Cover assemblies (4-bolt), 8", no heater	Quantity per		spare part code
	fitting	spare part	
unidirectional, standard prism	1	1	SP.AS00019-5NG
unidirectional, reinforced prism	1	1	SP.AS00019-5NS

A1 - Top Cover assemblies (4-bolt), 8", with heater	Quantity per		spare part code
	fitting	spare part	
unidirectional, standard prism, non-monitored (S-BAP) and EQ (R)	1	1	SPAS00019-5AG
unidirectional, reinforced prism, non-monitored (S-BAP) and EQ (R)	1	1	SPAS00019-5AS
unidirectional, standard prism, non-monitored (S-non-BAP) and monitored (M)	1	1	SPAS00019-5BG
unidirectional, reinforced prism, non-monitored (S-non-BAP) and monitored (M)	1	1	SPAS00019-5BS

B1 - Light engine assembly, 12"	Quantity per		spare part code
	fitting	spare part	
ICAO and FAA L-850B(L), white, left toe	1	1	SPAS00023-LW2
ICAO and FAA L-850B(L), white, straight	1	1	SPAS00023-SW2
ICAO and FAA L-850B(L), white, right toe	1	1	SPAS00023-RW2

B1 - Light engine assembly, 8"	Quantity per		spare part code
	fitting	spare part	
ICAO and FAA L-850B(L), white, left toe	1	1	SPAS00020-LW2
ICAO and FAA L-850B(L), white, straight	1	1	SPAS00020-SW2
ICAO and FAA L-850B(L), white, right toe	1	1	SPAS00020-RW2

C - Bottom pan assembly, 12"	Quantity per		spare part code
	fitting	spare part	
non-monitored converter, style 6 cord set	1	1	SPAS00024-L13
non-monitored converter, 3-pole cord set	1	1	SPAS00024-L1F
non-monitored converter, style 1 SJO jacketed cord set	1	1	SPAS00024-L1J
monitored converter, style 6 cord set	1	1	SPAS00024-M13
monitored converter, 3-pole cord set	1	1	SPAS00024-M1F
monitored converter, style 1 SJO jacketed cord set	1	1	SPAS00024-M1J
EQ converter, style 6 cord set	1	1	SPAS00024-R13
EQ converter, 3-pole cord set	1	1	SPAS00024-R1F
EQ converter, style 1 SJO jacketed cord set	1	1	SPAS00024-R1J
Buy American Preference non-monitored converter, style 6 cord set	1	1	SPAS00024-S13
Buy American Preference non-monitored converter, style 1 so cord set	1	1	SPAS00024-S1J

C - Bottom pan assembly, 8"	Quantity per		spare part code
	fitting	spare part	
non-monitored converter, style 6 cord set	1	1	SPAS00021-L13
non-monitored converter, 3-pole cord set	1	1	SPAS00021-L1F
non-monitored converter, style 1 SJO jacketed cord set	1	1	SPAS00021-L1J
monitored converter, style 6 cord set	1	1	SPAS00021-M13
monitored converter, 3-pole cord set	1	1	SPAS00021-M1F

C - Bottom pan assembly, 8"	Quantity per		spare part code
	fitting	spare part	
monitored converter, style 1 SJO jacketed cord set	1	1	SPAS00021-M1J
EQ converter, style 6 cord set	1	1	SPAS00021-R13
EQ converter, 3-pole cord set	1	1	SPAS00021-R1F
EQ converter, style 1 SJO jacketed cord set	1	1	SPAS00021-R1J
Buy American Preference non-monitored converter, style 6 cord set	1	1	SPAS00021-S13
Buy American Preference non-monitored converter, style 1 SJO jacketed cord set	1	1	SPAS00021-S1J

Cordsets	Quantity per		spare part code
	fitting	spare part	
Cord set, L-823 style 1, 8" bottom pan	1 or 2	5	SP.73A0193/1
Cord set, L-823 style 1, 12" bottom pan	1 or 2	5	SP.73A0194/1
Cord set, L-823 style 6, 8" & 12" bottom pan	1 or 2	5	SPSGE96253351
Cord set, 3-pole, 8" & 12" bottom pan	1 or 2	5	SPSGEFR500160
Cable retaining clamp, for use with style 1 cord set	1 or 2	5	SP.MB00003-013-01
Ground lug kit	1	5	SP.72A0401

Prism spares	Quantity per		spare part code
	fitting	spare part	
Prism kit, runway standard	1 or 2	2	SP.MG00001-G00-03
Prism kit, runway reinforced	1 or 2	2	SP.MG00001-S00-03
Prism gasket, Runway	1 or 2	10	SP.MS00004-000-02

Screws & gaskets	Quantity per		spare part code
	fitting	spare part	
Pressure release screw with o-ring	1	5	SP.MF00090-000-01
Gasket, 8" Bottom pan	1	10	SP.MS00005-000-01
Screws, 8" Bottom pan	-	100	SP.MFPM5PT-714-01
Gasket, 12" Bottom pan	1	10	SP.MS00006-000-01
Screws, light engine assembly mounting	-	100	SP.MFPM4PT-710-01
Screws, 12" Bottom pan	-	100	SP.MFPM6PT-720-01

Heater kits	Quantity per		spare part code
	fitting	spare part	
Heater kit with harness - non-monitored (S-BAP) & EQ	1 or 2	2	SPEP00038-R00-01
Heater kit with harness - non-monitored (S-non-BAP) & monitored	1 or 2	2	SPEP00038-R01-01

Wire harness	Quantity per		spare part code
	fitting	spare part	
Wire harness, power supply to light engine	1 or 2	10	SPEW00079-000-01

Fuse	Quantity per		spare part code
	fitting	spare part	
Fuse Resistors (only for fixtures with monitoring (M))	1 or 2	20	6132.00.250



Note

All screws for fastening are included.

Component availability or design may be subject to change due to unforeseen circumstances. This document is subject to change or new information from ADB SAFEGATE, as and when available or if required, with reservation for error or price changes.

For more information or assistance with ordering spare parts, contact ADB SAFEGATE, see www.adbsafegate.com.

7.5 Spare Parts - Threshold FAA, Threshold/End FAA, Runway End ICAO & FAA



Note

- Each Top Cover Assembly includes a Bottom Cover Gasket and a Bottom Cover Screws.
- BAP stands for "Buy American Preference".

A2 - Top Cover assemblies, 12", no heater	Quantity per		spare part code
	fitting	spare part	
unidirectional, standard prism	1	1	SPAS00018-UNG
unidirectional, reinforced prism	1	1	SPAS00018-UNS
bidirectional, standard prism	1	1	SPAS00018-BNG
bidirectional, reinforced prism	1	1	SPAS00018-BNS

A2 - Top Cover assemblies, 12", with heater	Quantity per		spare part code
	fitting	spare part	
unidirectional, standard prism, non-monitored (S-BAP) and EQ (R)	1	1	SPAS00018-UAG
unidirectional, reinforced prism, non-monitored (S-BAP) and EQ (R)	1	1	SPAS00018-UAS
unidirectional, standard prism, non-monitored (S-non-BAP) and monitored (M)	1	1	SPAS00018-UBG
unidirectional, reinforced prism, non-monitored (S-non-BAP) and monitored (M)	1	1	SPAS00018-UBS
bidirectional, standard prism, non-monitored (S-BAP) and EQ (R)	1	1	SPAS00018-BAG
bidirectional, reinforced prism, non-monitored (S-BAP) and EQ (R)	1	1	SPAS00018-BAS
bidirectional, standard prism, non-monitored (S-non-BAP) and monitored (M)	1	1	SPAS00018-BBG
bidirectional, reinforced prism, non-monitored (S-non-BAP) and monitored (M)	1	1	SPAS00018-BBS

B - Light engine assembly, 12"	Quantity per		spare part code
	fitting	spare part	
threshold, FAA L-850D(L), F-green, left toe	1	1	SPAS00023-LF2-RT
threshold, FAA L-850D(L), F-green, straight	1	1	SPAS00023-SF2
threshold, FAA L-850D(L), F-green, right toe	1	1	SPAS00023-RF2-RT
runway end, ICAO and FAA L-850D(L), red, straight	1 or 2	1	SPAS00023-SR3

C - Bottom pan assembly, 12"	Quantity per		spare part code
	fitting	spare part	
non-monitored converter, style 6 cord set	1	1	SPAS00024-L13
non-monitored converter, style 1 SJO jacketed cord set	1	1	SPAS00024-L1J
non-monitored converter, 2-con style 6 cord sets	1	1	SPAS00024-L23
non-monitored converter, 2-con style 1 SJO jacketed cord sets	1	1	SPAS00024-L2J
monitored converter, style 6 cord set	1	1	SPAS00024-M13
monitored converter, style 1 SJO jacketed cord set	1	1	SPAS00024-M1J

C - Bottom pan assembly, 12"	Quantity per		spare part code
	fitting	spare part	
monitored converter, 2-con style 6 cord sets	1	1	SPAS00024-M23
monitored converter, 2-con style 1 SJO jacketed cord sets	1	1	SPAS00024-M2J
EQ converter, style 6 cord set	1	1	SPAS00024-R13
EQ converter, style 1 SJO jacketed cord set	1	1	SPAS00024-R1J
Buy American Preference non-monitored converter, style 6 cord set	1	1	SPAS00024-S13
Buy American Preference non-monitored converter, style 1 so cord set	1	1	SPAS00024-S1J

Cordsets	Quantity per		spare part code
	fitting	spare part	
Cord set, L-823 style 1, 8" bottom pan	1 or 2	5	SP73A0193/1
Cord set, L-823 style 1, 12" bottom pan	1 or 2	5	SP73A0194/1
Cord set, L-823 style 6, 8" & 12" bottom pan	1 or 2	5	SPSGE96253351
Cable retaining clamp, for use with style 1 cord set	1 or 2	5	SPMB00003-013-01
Ground lug kit	1	5	SP72A0401

Prism spares	Quantity per		spare part code
	fitting	spare part	
Prism kit, runway standard	1 or 2	2	SPMG00001-G00-03
Prism kit, runway reinforced	1 or 2	2	SPMG00001-S00-03
Prism gasket, Runway	1 or 2	10	SPMS00004-000-02

Screws & gaskets	Quantity per		spare part code
	fitting	spare part	
Pressure release screw with o-ring	1	5	SPMF00090-000-01
Gasket, 12" Bottom pan	1	10	SPMS00006-000-01
Screws, light engine assembly mounting	-	100	SPMFPM4PT-710-01
Screws, 12" Bottom pan	-	100	SPMFPM6PT-720-01

Heater kits	Quantity per		spare part code
	fitting	spare part	
Heater kit with harness - non-monitored (S-BAP) & EQ	1 or 2	2	SP.EP00038-R00-01
Heater kit with harness - non-monitored (S-non-BAP) & monitored	1 or 2	2	SP.EP00038-R01-01

Wire harness	Quantity per		spare part code
	fitting	spare part	
Wire harness, power supply to light engine	1 or 2	10	SP.EW00079-000-01

Fuse	Quantity per		spare part code
	fitting	spare part	
Fuse Resistors (only for fixtures with monitoring (M))	1 or 2	20	6132.00.250



Note

All screws for fastening are included.

Component availability or design may be subject to change due to unforeseen circumstances. This document is subject to change or new information from ADB SAFEGATE, as and when available or if required, with reservation for error or price changes.

For more information or assistance with ordering spare parts, contact ADB SAFEGATE, see www.adbsafegate.com.

7.6 Spare Parts - Runway Status, Takeoff/Hold, Runway Intersection and Runway Entry Light



Note

- Each Top Cover Assembly includes a Bottom Cover Gasket and a Bottom Cover Screws.
- BAP stands for "Buy American Preference".

A2 - Top Cover assemblies, 12", no heater	Quantity per		spare part code
	fitting	spare part	
unidirectional, standard prism	1	1	SPAS00018-UNG
unidirectional, reinforced prism	1	1	SPAS00018-UNS

A2 - Top Cover assemblies, 12", with heater	Quantity per		spare part code
	fitting	spare part	
unidirectional, standard prism, EQ (R)	1	1	SPAS00018-UAG
unidirectional, reinforced prism, EQ (R)	1	1	SPAS00018-UAS
unidirectional, standard prism, monitored (M)	1	1	SPAS00018-UBG
unidirectional, reinforced prism, monitored (M)	1	1	SPAS00018-UBS

A1 - Top Cover assemblies (2-bolt), 8", no heater	Quantity per		spare part code
	fitting	spare part	
unidirectional, standard prism	1	1	SPAS00019-3NG
unidirectional, reinforced prism	1	1	SPAS00019-3NS

A1 - Top Cover assemblies (2-bolt), 8", with heater	Quantity per		spare part code
	fitting	spare part	
unidirectional, standard prism, EQ (R)	1	1	SPAS00019-3AG
unidirectional, reinforced prism, EQ (R)	1	1	SPAS00019-3AS
unidirectional, standard prism, monitored (M)	1	1	SPAS00019-3BG
unidirectional, reinforced prism, monitored (M)	1	1	SPAS00019-3BS

A1-Top Cover assemblies (4-bolt), 8", no heater	Quantity per		spare part code
	fitting	spare part	
4-bolt unidirectional, standard prism	1	1	SPAS00019-5NG
4-bolt unidirectional, reinforced prism	1	1	SPAS00019-5NS

A1-Top Cover assemblies (4-bolt), 8", with heater	Quantity per		spare part code
	fitting	spare part	
unidirectional, standard prism, EQ (R)	1	1	SPAS00019-5AG
unidirectional, reinforced prism, EQ (R)	1	1	SPAS00019-5AS
unidirectional, standard prism, monitored (M)	1	1	SPAS00019-5BG
unidirectional, reinforced prism, monitored (M)	1	1	SPAS00019-5BS

B1 - Light engine assembly	Quantity per		spare part code
	fitting	spare part	
runway status 12" take-off/hold light, red	1	1	SPAS00023-SR2
runway status 8" take-off/hold light, red	1	1	SPAS00020-SR2

C - Bottom pan assembly, 12"	Quantity per		spare part code
	fitting	spare part	
monitored converter, style 6 cord set	1	1	SPAS00021-M13
monitored converter, style 1 SJO jacketed cord set	1	1	SPAS00021-M1J
RWSL EQ converter, style 6 cord set	1	1	SPAS00021-R13
RWSL EQ converter, style 1 SJO jacketed cord set	1	1	SPAS00021-R1R

C - Bottom pan assembly, 8"	Quantity per		spare part code
	fitting	spare part	
monitored converter, style 6 cord set	1	1	SPAS00021-M13
monitored converter, style 1 SJO jacketed cord set	1	1	SPAS00021-M1J
RWSL EQ converter, style 6 cord set	1	1	SPAS00021-R13
RWSL EQ converter, style 1 SJO jacketed cord set	1	1	SPAS00021-R1R

Cordsets	Quantity per		spare part code
	fitting	spare part	
Cord set, L-823 style 1, 8" bottom pan	1 or 2	5	SP.73A0193/1
Cord set, L-823 style 1, 12" bottom pan	1 or 2	5	SP.73A0194/1
Cord set, L-823 style 6, 8" & 12" bottom pan	1 or 2	5	SP.SGE96253351
Cable retaining clamp, for use with style 1 cord set	1 or 2	5	SP.MB00003-013-01

Prism spares	Quantity per		spare part code
	fitting	spare part	
Prism kit, runway standard	1 or 2	2	SP.MG00001-G00-03
Prism kit, runway reinforced	1 or 2	2	SP.MG00001-S00-03
Prism gasket, Runway	1 or 2	10	SP.MS00004-000-02

Screws & gaskets	Quantity per		spare part code
	fitting	spare part	
Pressure release screw with o-ring	1	5	SP.MF00090-000-01
Gasket, 8" Bottom pan	1	10	SP.MS00005-000-01
Screws, 8" Bottom pan	-	100	SP.MFPM5PT-714-01
Gasket, 12" Bottom pan	1	10	SP.MS00006-000-01
Screws, light engine assembly mounting	-	100	SP.MFPM4PT-710-01
Screws, 12" Bottom pan	-	100	SP.MFPM6PT-720-01

Heater kits	Quantity per		spare part code
	fitting	spare part	
Heater kit with harness - non-monitored (S-BAP) & EQ	1 or 2	2	SP.EP00038-R00-01
Heater kit with harness - non-monitored (S-non-BAP) & monitored	1 or 2	2	SP.EP00038-R01-01

Wire harness	Quantity per		spare part code
	fitting	spare part	
Wire harness, power supply to light engine	1 or 2	10	SPEW00079-000-01

Fuse	Quantity per		spare part code
	fitting	spare part	
Fuse Resistors (only for fixtures with monitoring (M))	1 or 2	20	6132.00.250



Note

All screws for fastening are included.

Component availability or design may be subject to change due to unforeseen circumstances. This document is subject to change or new information from ADB SAFEGATE, as and when available or if required, with reservation for error or price changes.

For more information or assistance with ordering spare parts, contact ADB SAFEGATE, see www.adbsafegate.com.

8.0 Definition of Light Emission Directions

Light fixtures that have a toe-in are marked with an arrow to ensure a correct installation with regard towards the toe-in. The light fixtures should be installed with the arrow pointing towards the centerline.

The color and direction of the emitted light is indicated with a painted line on the top cover in front of the prism. On angled lines the light beam is emitted in the direction of the line. Sides with a straight line have a straight light beam.

The bidirectional light fixtures are all marked with A and B direction on the top plate and also on the outside of the bottom cover. This is to help orienting the top during installation and to keep track of the color and toe-in of each side.

Figure 58: Light emission directions

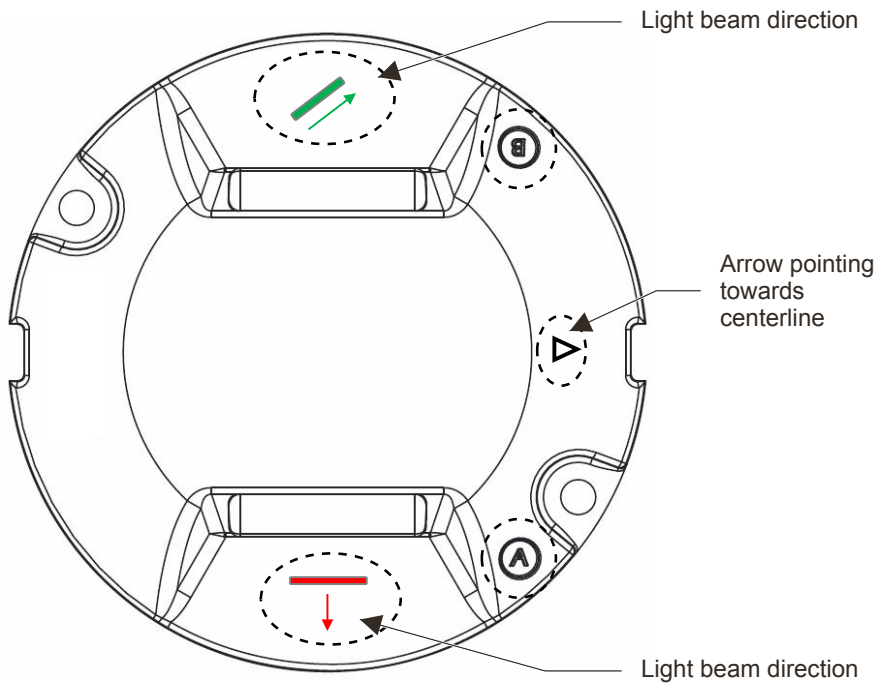

Appendix A: POWER TABLE

LED L-850A(L), L-850B(L) Runway Centerline and Touchdown Zone

(RC-RZ), **without** Arctic Kit

Fixture type – 1 cord set ¹	Fixture load	Isolation transformer		CCR load
		Wattage	Load	
Runway Centerline, L-850A(L), bidirectional	34.9 VA	45 W	14.2 VA	49.1 VA
Touchdown Zone, L-850B(L), unidirectional	25.5 VA	25 W	7.2 VA	32.7 VA

(RC-RZ), **with** Arctic Kit

Fixture Types – 1 cord set ¹	Fixture load	Isolation transformer		CCR load
		Wattage	Load	
Runway Centerline, L-850A(L), bidirectional	62.6 VA	65 W	16.6 VA	79.2 VA
Touchdown Zone, L-850B(L), unidirectional	48.8 VA	45 W	9.7 VA	58.5 VA

Notes

¹ Values provided are for the "S" option non-monitored power only.

LED L-850C(L) Runway Edge

(RE 45 m), **without** Arctic Kit

Fixture type – 1 cord set ¹	Fixture load	Isolation transformer		CCR load
		Wattage	Load	
Runway Edge, L-850C(L), bidirectional	60.7 VA	65 W	17.4 VA	78.1 VA

(RE 45 m), **with** Arctic Kit

Fixture type – 1 cord set ¹	Fixture load	Isolation transformer		CCR load
		Wattage	Load	
Runway Edge, L-850C(L), bidirectional	71.6 VA	65 W	15.7 VA	87.3 VA

Notes

¹ Values provided are for the "S" option non-monitored power only.

L-850D(L) LED Runway Threshold, End, Threshold/End

(RN-RT FAA), **without** Arctic Kit

Fixture type – 1 cord set ¹	Fixture load	Isolation transformer		CCR load
		Wattage	Load	
Runway Threshold, L-850D(L), bidirectional, F-Green/red	36.6 VA	45 W	14.2 VA	50.8 VA
Runway Threshold, L-850D(L), bidirectional, red/red	46.6 VA	45 W	13 VA	59.6 VA
Runway Threshold, L-850D(L), unidirectional, F-Green	21.2 VA	25 W	6.8 VA	28 VA
Runway Threshold, L-850D(L), unidirectional, red	31.6 VA	25 W	9.5 VA	41.1 VA

(RN-RT FAA), **with** Arctic Kit

Fixture type – 1 cord set ¹	Fixture load	Isolation transformer		CCR load
		Wattage	Load	
Runway Threshold, bidirectional, L-850D(L), F-Green/red	65.3 VA	65 W	16.2 VA	81.5 VA
Runway Threshold, L-850D(L), unidirectional, F-Green	49.4 VA	45 W	10 VA	59.4 VA

Notes

¹ Values provided are for the "S" option non-monitored power only.

Runway Status L-850T(L), Takeoff/Hold, Runway Intersection (THL/RIL) and Runway Entry Light (REL)

(RS-TS), **without** Arctic Kit

Fixture type – 1 cord set	Fixture load	Isolation transformer		CCR load
		Wattage	Load	
L-850T(L) THL/RIL Takeoff Hold Light	16.5 VA	25 W	10 VA	26.5 VA
REL Runway Entry Light	17.5 VA	25 W	9.8 VA	27.3 VA

(RS-TS), **with** Arctic Kit

Fixture type – 1 cord set	Fixture load	Isolation transformer		CCR load
		Wattage	Load	
L-850T(L) THL/RIL Takeoff Hold Light	48.5 VA	65 W	14 VA	62.5 VA
REL Runway Entry Light	49.5 VA	65 W	14 VA	63.5 VA

LED Stopway , ≤ 45 m Width

(RS-SW), without arctic kit

Fixture type – 1 cord set	Fixture load	Isolation transformer		CCR load
		Wattage	Load	
Stopway Unidirectional	VA	W	VA	VA

(RS-RW), with arctic kit

Fixture type – 1 cord set	Fixture load	Isolation transformer		CCR load
		Wattage	Load	
Stopway Unidirectional	VA	W	VA	VA

Appendix B: INTEROPERABILITY

Base installation – O-ring selection and retaining bolts 12-inch

For 12-inch light fixtures the O-ring is required. Refer to data sheet for ordering code for corresponding 12-inch base.



CAUTION

Use of incorrect combination of gaskets, bolts and nuts can create severe damages to the product installation and create multiple safety risks.

To obtain a safe and watertight installation the O-ring and retaining bolt stated in the document must be used.

You need to know what base the light fixture will be installed in, in order to choose the correct gasket, bolts and nuts.

Failure to follow these cautions can result in equipment damage or aircraft FOD.

Table 2: Interoperability matrix — 12 inch

Base type	Required O-ring	Bolt installation		Stud installation	
		Required dimension	Recommended torque	Required nut	Recommended torque
<ul style="list-style-type: none"> RELIANCE 12"-(150 mm) Safegate 12"-(150 mm) ERNI 12-in ED12-190 	O-ring D259, 3×5,7 (7080.90.650) SP013114/10pc SP013115/100pc	1411.20.482 Metric screw kit 12-in M10×25 mm	40 Nm + locking washer (max height 2mm)	1411.20.500 Self-locking nut kit 12-in M10 H=100	35 Nm
<ul style="list-style-type: none"> Thorn 12-in (150 mm) Thorn 12-in (100mm) 	O-ring D259, 3×5,7 (7080.90.650) SP013114/10pc SP013115/100pc	1411.20.482 Metric screw kit 12-in M10×25 mm	40 Nm + locking washer (max height 2mm) *only with non-roll over lights	1411.20.500 Metric nut kit 12-in M10 H=100	35 Nm *only with non-roll over lights
<ul style="list-style-type: none"> L-868 deep can with flange 	O-ring D259, 3×5,7 (7080.90.650) SP013114/10pc SP013115/100pc	1411.20.482 Metric screw kit 12-in M10×25 mm	40 Nm + Loctite 638	1411.20.500 Self-locking nut kit 12-in M10 H=100	35 Nm + Loctite 638
<ul style="list-style-type: none"> ADB 12-in Eurobase 	O-ring D259, 3×5,7 (7080.90.650) SP013114/10pc SP013115/100pc	1411.22.482 Metric screw kit 12-in M10×22 mm	21 Nm + Loctite 2701 or 638	1411.20.500 Self-locking nut kit 12-in M10 H=100	21 Nm + Loctite 2701 or 638

Table 3: Interoperability matrix — 8 inch

Base type	Required O-ring	Bolt installation		Stud installation	
		Required dimension	Recommended torque	Required nut	Recommended torque
<ul style="list-style-type: none"> ERNI 8-in EE08 (150 mm) ERNI 8-in ED08 (133 mm) 	Blue O-Ring (SGE48001263) SGE.SP24521/10 pc SGE.SP24524/100 pc	1411.20.522 Metric screw kit 8" 25 mm	40 Nm + locking washer (max height 2mm)	1411.20.430 Self-locking nut kit H100	35 Nm
<ul style="list-style-type: none"> Thorn 8-in (100 mm) Thorn 8-in (133 mm) IDM 6494 (120 mm) 	Red O-Ring (SGE48001298) SGE.SP24523/10 pc SGE.SP24526/100 pc	1411.20.522 Metric screw kit 8" 25 mm	40 Nm + locking washer (max height 2mm)	1411.20.430 Self-locking nut kit H100	35 Nm
<ul style="list-style-type: none"> ADB 8-in Eurobase 	Blue O-Ring (SGE48001263) SGE.SP24521/10 pc SGE.SP24524/100 pc	1411.20.522 Metric screw kit 8" 25 mm	21 Nm + Loctite 2701 or 638	1411.20.430 Self-locking nut kit H100	No Loctite to be used on Self-locking nut nor a washer

Table 3: Interoperability matrix — 8 inch (Continued)

Base type	Required O-ring	Bolt installation		Stud installation	
		Required dimension	Recommended torque	Required nut	Recommended torque
• ADB 8-in HPI	Grey O-Ring (SGE48001264) SGE.SP24522/10 pc SGE.SP24525/100 pc	1411.20.522 Metric screw kit 8" 25 mm	21 Nm + Loctite 2701 or 638	1411.20.430 Self-locking nut kit H100	No Loctite to be used on Self-locking nut nor a washer
• Adapter ring ADB 8-in–12-in	Blue O-Ring (SGE48001263) SGE.SP24521/10 pc SGE.SP24524/100 pc	1411.20.522 Metric screw kit 8" M10x25 mm	21 Nm + Loctite 2701 or 638	1411.20.430 Self-locking nut kit 8" M10 H100	No Loctite to be used on Self-locking nut nor a washer
• Adapter ring SG/ Thorn/ID 8-in– 12-in	Red O-Ring (SGE48001298) SGE.SP24523/10 pc SGE.SP24526/100 pc	1411.20.522 Metric screw kit 8" M10x25 mm	40 Nm + locking washer (max height 2mm)	1411.20.430 Self-locking nut kit H100	35 Nm



0

Appendix C: CABLE LOSS

The cable resistance R (ohms) for 1 conductor is calculated with following formula:

- $R \text{ (ohms)} = \text{resistivity of material (ohm m)} \times \text{length (m)} / \text{cross sectional area (m}^2\text{)}$
- For copper conductors the resistivity is $1.72 \cdot 10^{-8} \text{ (m}^2\text{)}$

Example; for 1 km 2.5 mm^2 copper conductor, the resistance R is calculated as follows:

$$1.72 \cdot 10^{-8} \times 1000 / 2.5 \cdot 10^{-6} \text{ m}^2 = 6.88 \text{ ohms}$$

The loss (Watt) is then $R \times I^2$ or $6.88 \text{ ohms} \times 6.6^2 \text{ A}^2 = 299.69 \text{ W/km}$ or 0.299 W/m .

The loss (Watt) for a secondary cable with 2 conductors is thus $2 \times 0.299 = 0.599$ or 0.6 W/m .

As such we can calculate:

- Secondary cable for a 2.5 mm^2 Cu-wire (2 conductors): 0.6 W/m
- Secondary cable for a 4 mm^2 Cu-wire (2 conductors): 0.4 W/m
- Primary cable for a 6 mm^2 Cu-wire (1 conductor): 0.12 W/m

The cable between the isolation transformer and the lamp adds losses that cannot be ignored when dimensioning the circuits and selecting rating for secondary transformers and regulators.



WARNING

Cable lengths should not exceed 100 meters.

For a secondary cable of e.g., 20 m of 2.5 mm^2 CU-wire, $20 \text{ m} \times 0.6 \text{ W/m} = 12 \text{ W}$ equals the additional loss to be taken into account.

For a primary cable of e.g., 100 m of 6 mm^2 CU-wire, $100 \text{ m} \times 0.12 \text{ W/m} = 12 \text{ W}$ equals the additional loss to be taken into account.

Appendix D: SUPPORT

Our experienced engineers are available for support and service at all times, 24 hour/7 days a week. They are part of a dynamic organization making sure the entire ADB SAFEGATE is committed to minimal disturbance for airport operations.

ADB SAFEGATE Support

Live Technical Support - Americas

If at any time you have a question or concern about your product, just contact ADB SAFEGATE's technical service department. Trained in all areas of system issues, troubleshooting, quality control and technical assistance, our highly experienced Technical support specialists are available 24 hours a day, seven days a week to provide assistance over the phone.

ADB SAFEGATE **Americas Technical Service & Support (US & Canada): +1-800-545-4157**

ADB SAFEGATE Americas Technical Service & Support (International): +1-614-861-1304

During regular business hours, you can also Chat with a Service Technician. We look forward to working with you!

Before You Call

When you have an airfield lighting or system control system problem it is our goal to support airfield maintenance staff as quickly as possible. To support this effort we ask that you have the following information ready before calling.

- The *airport code*
- If not with an airport, then company name (prefer customer id number)
- Contact phone number and email address
- Product with part number preferable or product number
- Have you reviewed the product's manual and troubleshooting guide
- Do you have a *True RMS* meter available (and any other necessary tools)
- Be located with the product ready to troubleshoot

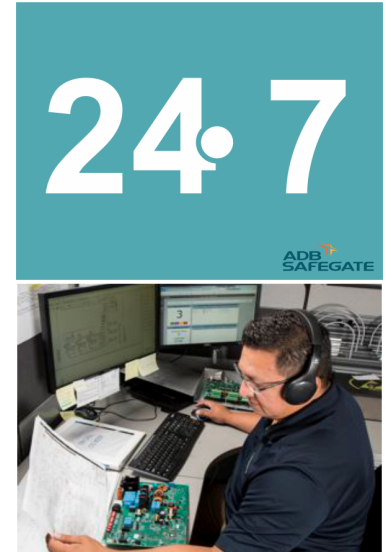

Note

For more information, see www.adbsafegate.com, or contact ADB SAFEGATE Support via email at support@adbsafegate.com or

Brussels: +32 2 722 17 11

Rest of Europe: +46 (0) 40 699 17 40

Americas: +1 614 861 1304. Press 3 for technical service or press 4 for sales support.

China: +86 (10) 8476 0106

D.1 ADB SAFEGATE Website

The ADB SAFEGATE website, www.adbsafegate.com, offers information regarding our airport solutions, products, company, news, links, downloads, references, contacts and more.

D.2 Recycling

D.2.1 Local Authority Recycling

The disposal of ADB SAFEGATE products is to be made at an applicable collection point for the recycling of electrical and electronic equipment. The correct disposal of equipment prevents any potential negative consequences for the environment and human health, which could otherwise be caused by inappropriate waste handling. The recycling of materials helps to conserve natural resources. For more detailed information about recycling of products, contact your local authority city office.

D.2.2 ADB SAFEGATE Recycling

ADB SAFEGATE is fully committed to environmentally-conscious manufacturing with strict monitoring of our own processes as well as supplier components and sub-contractor operations. ADB SAFEGATE offers a recycling program for our products to all customers worldwide, whether or not the products were sold within the EU.

ADB SAFEGATE products and/or specific electrical and electronic component parts which are fully removed/separated from any customer equipment and returned will be accepted for our recycling program.

All items returned must be clearly labeled as follows:

- For *ROHS/WEEE* Recycling
- Sender contact information (Name, Business Address, Phone number).
- Main Unit Serial Number.

ADB SAFEGATE will continue to monitor and update according for any future requirements for *EU directives* as and when *EU member states* implement new *regulations* and or *amendments*. It is our aim to maintain our *compliance plan* and assist our customers.

Company Addresses

ADB SAFEGATE, Belgium	ADB SAFEGATE BV Leuvensesteenweg 585, B-1930 Zaventem Belgium
Contact: Tel.: +32 2 722 17 11 Fax: +32 2 722 17 64	Email: marketing@adbsafegate.com Internet: www.adbsafegate.com
ADB SAFEGATE, Americas	ADB SAFEGATE Americas LLC 977 Gahanna Parkway, Columbus, OH 43230 USA
Contact: Tel.: +1 (614) 861 1304 Fax: +1 (614) 864 2069	Email: sales.us@adbsafegate.com Internet: www.adbsafegate.com
ADB SAFEGATE, Sweden	ADB SAFEGATE Sweden AB Djurhagegatan 19 SE-213 76 Malmö Sweden
Contact: Tel.: +46 (0)40 699 17 00 Fax: +46 (0)40 699 17 30	Email: marketing@adbsafegate.com Internet: www.adbsafegate.com
ADB SAFEGATE, China	ADB SAFEGATE Airfield Technologies Ltd. China Unit 603, D Block, CAMIC International Convention Center, No 3, Hua Jia Di East road, ChaoYang district, Beijing 100102 P.R. China
Contact: Tel.: +86 (10) 8476 0106 Fax: +86 (10) 8476 0090	Email: china@safegate.com Internet: www.adbsafegate.com
ADB SAFEGATE, Germany	ADB SAFEGATE Germany GmbH Konrad-Zuse-Ring 6, D-68163 Mannheim Germany
Contact: Tel.: +49 (621) 87 55 76-0 Fax: +49 (621) 87 55 76-55	Email: marketing@adbsafegate.com Internet: www.adbsafegate.com



Powering Your Airport Performance from Approach to Departure

adbsafegate.com

Copyright © ADB SAFEGATE, all rights reserved

